

CHEMISTRY

Workbook
Year 9

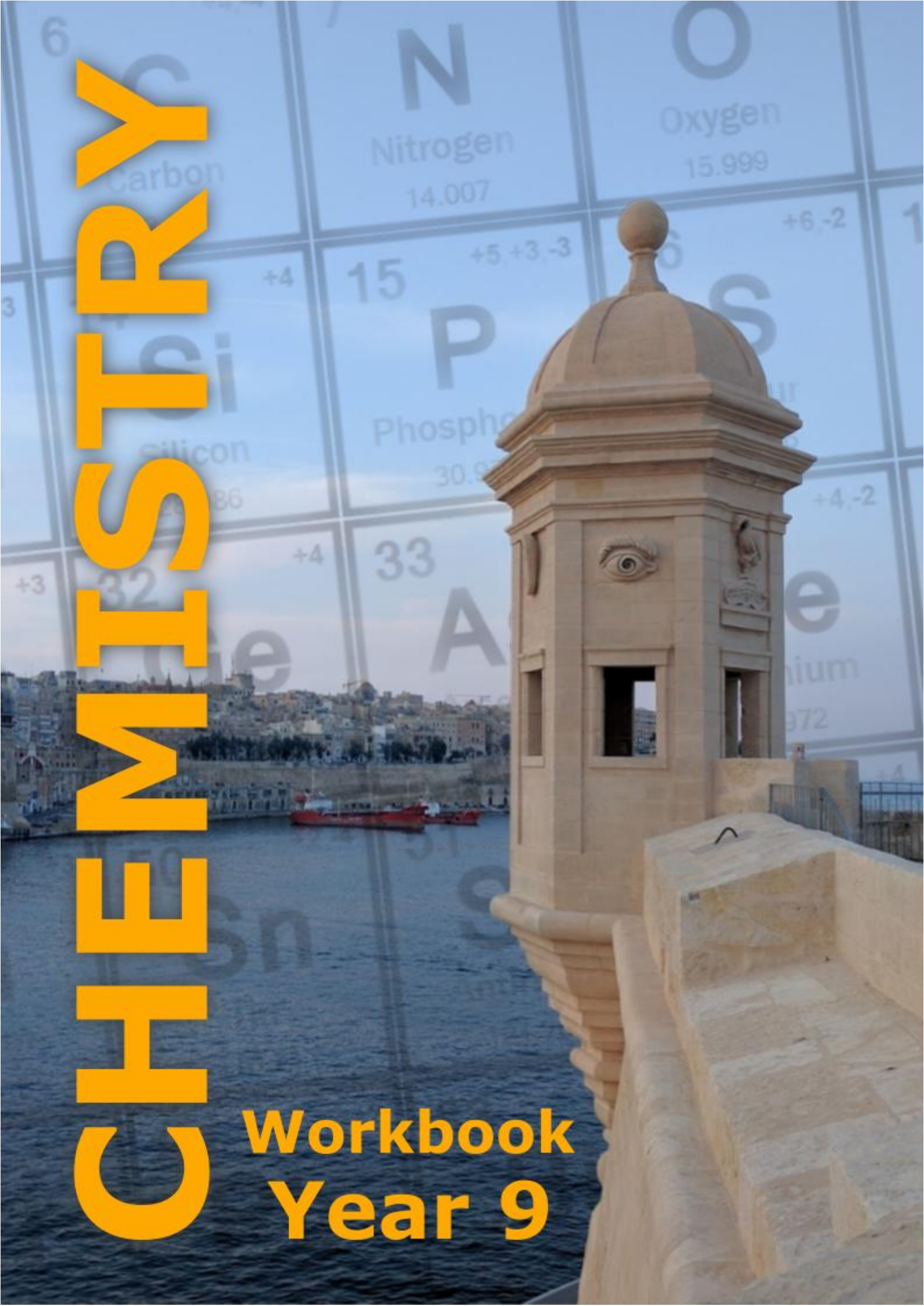

This workbook will be available in digital format (PDF) only. It is intended to be used by secondary school students and teachers in Malta and Gozo following a SEC06 Chemistry syllabus. This workbook is a companion to the Chemistry Year 9 textbook.

Version 2.0 distributed on July 2026.

Acknowledgements

The following persons contributed towards the content of this workbook: Rebecca Baldacchino (TR), Erika Micallef (TR), Doreen Mizzi (HOD), Luke Sammut (TR), and Lorraine Vella (TR).

Michael Mercieca (EO) and Doreen Mizzi (HOD) contributed towards editing this workbook.

Michael Mercieca (EO) contributed towards the compilation of this workbook.

How to use this workbook

The exercises found in this workbook are structured in a way that is closely linked to the Chemistry Year 9 textbook. The headings in this workbook run parallel to those in the textbook. This to allow easy access for both students and teachers.

Contents

1	UNDERSTANDING HOW CHEMISTRY WORKS AND IS COMMUNICATED (LO 1)	1
1.1	UNDERSTANDING THE SCIENTIFIC PROCESS	1
1.2	HEALTH AND SAFETY	2
1.3	PERFORMING EXPERIMENTS	4
2	GASES FOUND IN AIR AND THEIR LAB PREPARATION (LO 2)	7
2.1	GASES IN EARTH'S ATMOSPHERE	7
2.2	ELEMENTS, COMPOUNDS, AND MIXTURES	9
2.3	THE PERIODIC TABLE OF THE ELEMENTS	10
2.4	THE NUCLEAR MODEL - PROTONS, NEUTRONS, AND ELECTRONS	11
2.5	COVALENT BONDING	14
2.6	REPRESENTING CHEMICAL REACTIONS	15
2.7	DIFFUSION AND DENSITY OF GASES	16
2.8	PREPARING, COLLECTING, AND TESTING FOR GASES	17
2.9	ATMOSPHERIC POLLUTION	21
3	THE SOLVENT ACTION OF WATER INCLUDING THE IMPACT OF WATER HARDNESS (LO 3)	25
3.1	WATER – A SOURCE OF LIFE AND CONFLICT	25
3.2	POTABLE WATER SOURCES IN MALTA	26
3.3	PROPERTIES OF PURE WATER	27
3.4	MIXTURES	27
3.5	OBTAINING TABLE SALT	28
3.6	SALTS AND IONIC BONDING	30
3.7	SOLVENT ACTION OF WATER, SOLUTION, AND SOLUBILITY	37
3.8	HARD AND SOFT WATER	39
4	ACIDS, BASES, AND SALTS (LO 4)	42
4.1	INDICATORS	42
4.2	ACIDS	43
4.3	BASES AND ALKALIS	44
4.4	METALLIC AND NON-METALLIC OXIDES	45
4.5	ACID REACTIONS	46
4.6	APPLICATIONS OF ACID-BASE CONCEPTS IN REAL-LIFE SITUATIONS	48
4.7	SALTS	54
5	PHYSICAL AND CHEMICAL CHANGES (LO 9)	56
5.1	DISTINGUISHING BETWEEN PHYSICAL AND CHEMICAL CHANGES	56
5.2	THE THREE STATES OF MATTER AND 1.3 CHANGES OF STATE	59
6	FURTHER QUESTIONS	65
7	PERIODIC TABLE OF THE ELEMENTS	74

1 Understanding how chemistry works and is communicated (LO 1)

1.1 Understanding the scientific process

1. State whether the following statement is a theory, hypothesis, or fact:
 - a. The universe began due to an explosion called the Big Bang. _____ (1)
 - b. It takes 8 minutes and 19 seconds for light to travel from the Sun to the Earth. _____ (1)
 - c. Stomach acid is strong enough to dissolve stainless steel. _____ (1)
 - d. Mark will run faster than Gilbert as his legs are long, and he weighs less than Gilbert. _____ (1)
 - e. An acid will turn blue litmus paper to red. _____ (1)
 - f. It is thought that humans have evolved from apelike ancestors. _____ (1)
- (6 marks)

2. Until the 1500's the most influential theory on the movement of planets was that of Ptolemy. He claimed that the Earth was the centre of the universe and that the planets and stars revolve around the Earth.

In 1543 Copernicus published a book where his main argument was that it was more likely that the Sun was stationary, and that the Earth and other planets revolved around the sun. However, he could not prove that his theory was correct.

In 1609, Galileo built a telescope and observed that the moons of Jupiter were orbiting Jupiter instead of orbiting the Earth... therefore that must mean that Earth was not the centre of the Universe. In 1632, Galileo published a book supporting Copernicus' theory that the Earth revolved around the Sun.

- a. What does this information tell us about scientific theories?
_____ (1)
- b. Use the information above to compare Galileo's theory with that proposed by Copernicus.

_____ (2)
- c. Were Galileo's findings a theory or a hypothesis? Explain.

_____ (2)

(5 marks)

1.2 Health and safety

1. The picture below shows some students carrying out an experiment in a lab.

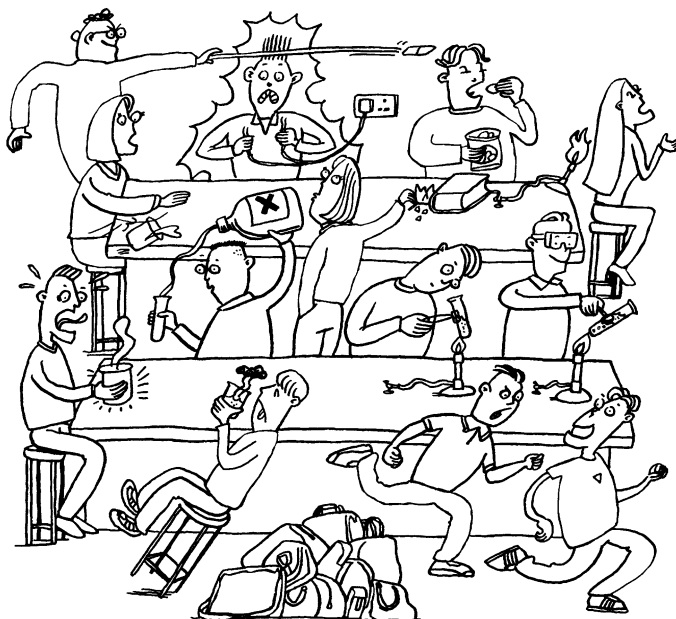

Using the picture to help you, list at least four safety rules which must always be followed in a chemistry laboratory.

(4 marks)

2. Mark holds a piece of magnesium ribbon over the Bunsen flame using tongs. Once it starts burning, he removes it from the Bunsen burner. Magnesium burns with a brilliant white light to produce white ash.









- a. Describe how the Bunsen flame appears when the air hole is
- closed _____ (1)
 - open _____ (1)

- b. State one precaution taken once the magnesium starts burning. Give a reason for your answer.

(2)

(4 marks)

3. Fill in the table below by writing the title for each hazard symbol.

Hazard	Symbol
	
	
	
	
	
	

(6 marks)

4. Consult the MSDS sheets and complete the following table by filling in the hazard and safety precaution taken when using the following chemicals.

Chemical	Hazard	Safety precaution
copper(II) oxide powder		
hydrochloric acid concentration 1.0 mol dm^{-3}		
magnesium ribbon		
sodium hydroxide concentration 1.0 mol dm^{-3}		

(8 marks)

1.3 Performing experiments

1. Label the apparatus in the following diagrams.

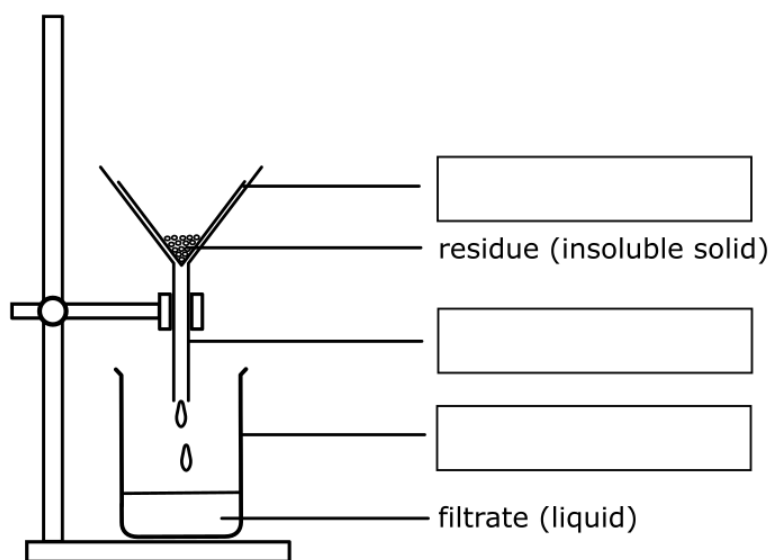
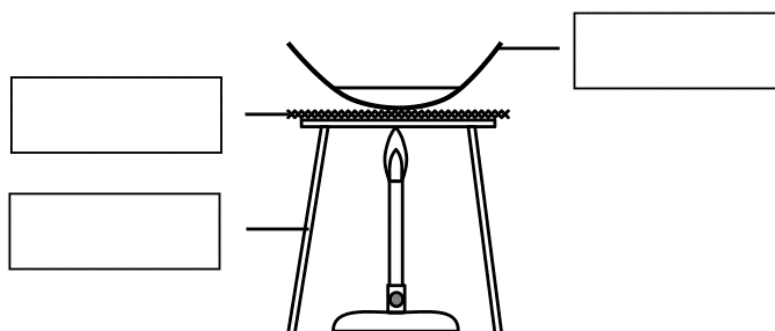

(6 marks)

2. The photo shows a setup where water is heated using a Bunsen burner, and the temperature is recorded. In the space below draw a labelled diagram of this set up.

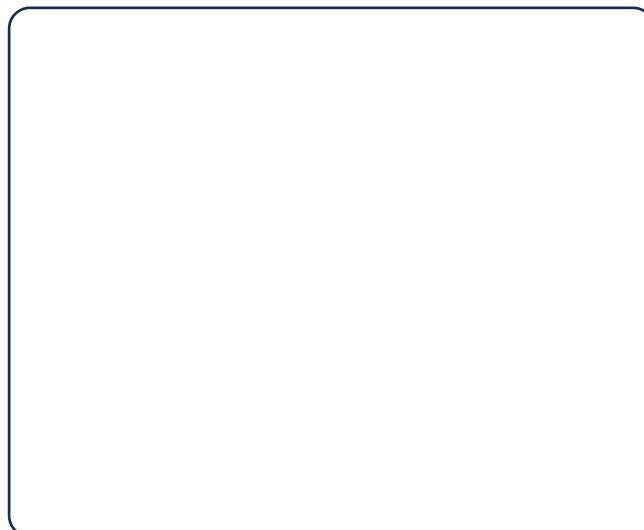

(6 marks)

3. Yeast is a microscopic organism used in bread making to make dough rise. It 'feeds' on sugar and breaks it down to release carbon dioxide gas. Mark and Suzie wanted to investigate how varying the amount of sugar affects the amount of carbon dioxide produced. They repeated the experiment four times using different amounts of sugar. They decided to collect the gas produced in balloons attached to the neck of the measuring cylinders as shown in Figure 1 below.

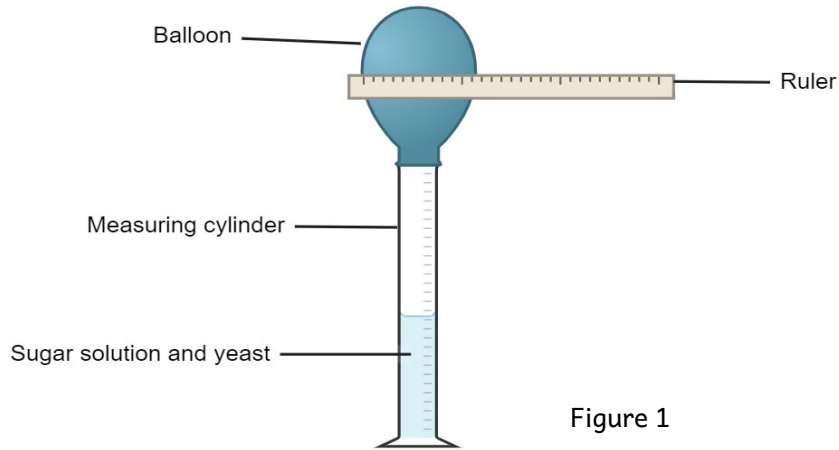

Figure 1

- a. What was the aim of this investigation?

_____ (1)

- b. Mark suggested that they should include a description of how large the balloon grew for each test-tube containing the varying amounts of sugar. Suzie suggested that they measure the diameter of the balloons. Explain why Suzie's approach is better than Mark's.

_____ (2)

- c. Identify the dependent and independent variables in this investigation.

Dependent variable: _____ (1)

Independent variable: _____ (1)

- d. Explain why it was important for Mark and Suzie to use the same amount of water and yeast in each test-tube.

_____ (2)

- e. Mention another precaution that Suzie and Mark could have taken to ensure more accurate results. Explain why this precaution is taken.

_____ (2)

f. The results from Mark and Suzie's experiment are shown in Table 1 below.

Table 1

Measuring cylinder no.	Water added (cm ³)	Yeast added (sachet/g)	Sugar added (g)	Diameter of balloon (cm)
1	50	1 sachet / 11	2	13
2	50	1 sachet / 11	4	32
3	50	1 sachet / 11	6	38
4	50	1 sachet / 11	8	41

i. Plot a line graph to show the effect of varying mass of sugar (x axis) on the diameter of the balloon (y axis). (6)

ii. Describe and explain the graph obtained.

_____ (2)

iii. Suggest **two** ways this experiment could be improved.

_____ (2)

g. Mark and Suzie's friend Lara decided to replicate the experiment using sanitizer as a solvent instead of water. Her results are summarised in Table 2 below.

Table 2

Measuring cylinder no	Sanitizer added (cm ³)	Yeast added (sachet/g)	Sugar added (g)	Diameter of balloon (cm)
1	50	1 sachet /11	2	0
2	50	1 sachet /11	4	0
3	50	1 sachet /11	6	0
4	50	1 sachet /11	8	0

i. Plot Lara's results on the same axis used in question f) i). Label this graph as 'g'. (2)

ii. Explain what can be concluded from Lara's results.

_____ (2)

(23 marks)

2 Gases found in air and their lab preparation (LO 2)

2.1 Gases in Earth's atmosphere

1. Give the name of:
 - a. the most abundant gas found in air. _____ (1)
 - b. the most reactive gas found in air. _____ (1)
 - c. one unreactive gas found in air. _____ (1)
 - d. one gas found in air which is a pollutant. _____ (1)
 - e. a gas used in fire extinguishers. _____ (1)
 - f. a gas needed for combustion. _____ (1)
 - g. a gas used in packaging food to keep it fresh. _____ (1)
 - h. a gas used by plants for photosynthesis. _____ (1)
 - i. an unreactive gas that is less dense than air. _____ (1)
 - i. a gas used in advertising signs. _____ (1)

(10 marks)

2. Nitrogen, oxygen, and the noble gases are the main gases found in air.
 - a. Give the percentage by volume of each of the above-mentioned gases.

 _____ (3)
 - b. Nitrogen and oxygen are diatomic molecules. Give the formula of nitrogen and that of oxygen and use these formulae to explain what diatomic means.

 _____ (3)
 - c. The noble gases are also called inert gases. What does the word inert mean?
 _____ (1)
 - d. Liquid nitrogen is very cold. Give a use for liquid nitrogen.
 _____ (1)

(8 marks)

3. This question is about the gases present in air.

The following diagram shows the apparatus that can be used to determine the percentage composition of one of the gases in air. At the beginning of the experiment, syringe A contained 100 cm^3 of air whereas syringe B was empty. The air in syringe A was passed forwards and backwards over the heated copper as shown in the diagram below.

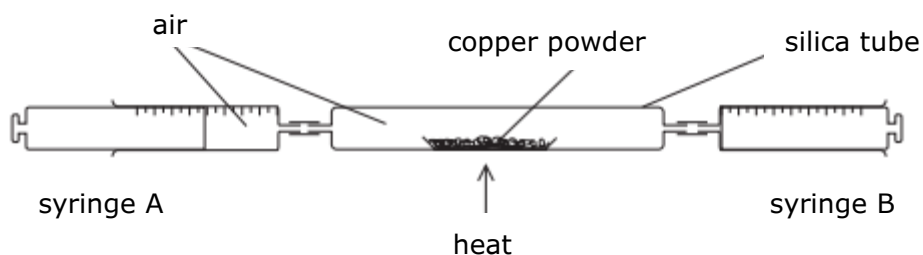

- a. How can the apparatus be tested for leaks before starting the experiment?

 _____ (1)
- b. Give the name of the gas in air that reacts with copper powder in the experiment.
 _____ (1)
- c. The apparatus is allowed to cool down before the final reading of air is taken at the end of the experiment. Give a reason for this statement.

 _____ (1)
- d. Give the approximate volume of gas expected to remain in syringe A at the end of the experiment. Name the main gas that is present at the end of the experiment.
 _____ (2)
- e. What is the name and colour of the solid left in the silica tube at the end of the experiment?
 Name: _____ (1)
 Colour: _____ (1)
- f. Write a word equation to represent the reaction of copper with the gas in the air.
 _____ (1)
- g. Write a balanced chemical equation to represent the reaction of copper with the gas in air.
 _____ (2)
- (10 marks)

2.2 Elements, compounds, and mixtures

1. Fill in the following table.

Compound	Names of elements in the compound	Total number of atoms in the compound
Na_2CO_3		
ZnO		
PbSO_4		
$(\text{NH}_4)_2\text{SO}_4$		
Al_2O_3		
KCl		
$\text{Cu}(\text{NO}_3)_2$		

(14 marks)

2. Use the following list of substances to answer the following questions:

air, carbon, chlorine, sulfur, hydrogen, mercury, table salt, sodium, water

- Which metal is a liquid at room temperature? _____ (1)
- Name the two elements present in table salt. _____ (1)
- Name a non-metal which is present in oil. _____ (1)
- Which element is yellow in colour? _____ (1)
- Name a compound. _____ (1)
- Name a mixture. _____ (1)

(6 marks)

3. Classify the following substances into mixtures, compounds, and elements.

rainwater, sea water, common salt, copper, air, gold,
aluminium oxide, ink, lead, magnesium oxide, tin, iron(II) sulfide

Mixtures	Compounds	Elements

(12 marks)

2.4 The nuclear model - protons, neutrons, and electrons

1. Fill in the following table to name the three subatomic particles in an atom, their relative masses, and charges.

PARTICLE	RELATIVE MASS	CHARGE

(9 marks)

2. Write the shorthand notation (A_ZX) for each of the following isotopes:

- a. Oxygen with 8 neutrons and 8 protons: _____ (1)
- b. Argon with 22 neutrons and 18 protons: _____ (1)
- c. Bromine with 45 neutrons and 35 protons: _____ (1)
- d. Chromium with 32 neutrons and 24 protons: _____ (1)

(4 marks)

3. Consider the atom ${}^{18}_8X$ where X is not the symbol of the element. What is the:

- a. atomic number of X? _____ (1)
- b. number of neutrons in an atom of X? _____ (1)
- c. number of electrons in an atom of X? _____ (1)
- d. mass number of X? _____ (1)
- e. electronic configuration of atom X? _____ (1)

(5 marks)

4. Fill in the missing information.

Element symbol	Atomic number	Mass number	Number of protons	Number of neutrons	Electron configuration
He	2		2	2	2
Na	11	23	11		2,8,1
P	15	31			2,8,5
S		32	16	16	
Cl	17	37	17		

(8 marks)

5. A sodium atom has an electron configuration of 2,8,1.

a. Draw and label a diagram to show how the electrons are arranged in a sodium atom.

(2)

b. Explain why a sodium atom is electrically uncharged.

(2)

c. Using your diagram explain why sodium is found in period 3.

(1)

d. Explain why sodium is found in group 1.

(1)

e. Name another group 1 element.

(1)

(7 marks)

6. Atom A has atomic number 82 and mass number 204. Atom B has atomic number 80 and mass number 204.

a. How many protons are in atom A? _____ (1)

b. How many neutrons are in atom B? _____ (1)

c. State whether atoms A and B are isotopes of the same element. Explain your answer.

(2)
(4 marks)

7. Given that the percentage abundance of Li-6 is 7.59% and that of Li-7 is 92.41%, calculate the relative atomic mass of lithium.

(3 marks)

8. Bromine is an element which exists as a mixture of two isotopic forms. A and B represent atoms of these two isotopes. They occur in equal numbers. A has a mass number of 79 whereas B has a mass number of 81. Their atomic number is 35.

a. State the number of:

i. protons in atom A: _____ (1)

ii. electrons in atom B: _____ (1)

iii. neutrons in atom A: _____ (1)

iv. neutrons in atom B: _____ (1)

b. Calculate the relative atomic mass of bromine.

 _____ (2)
 (6 marks)

9. Hydrogen ${}^1_1\text{H}$, deuterium ${}^2_1\text{H}$, and tritium ${}^3_1\text{H}$ are isotopes.

a. Define the word isotopes.

 _____ (2)

b. Complete the table:

	Hydrogen	Deuterium	Tritium
Atomic number			
Mass number			
Number of neutrons			
Number of electrons			

(6)

c. Explain why isotopes have the same chemical reactions.

 _____ (2)
 (10 marks)

10. Calculate the relative atomic mass of silicon given the existence of 3 silicon atoms with the following percentage abundance. 92.25% of ${}^{28}\text{Si}$, 4.7% of ${}^{29}\text{Si}$ and 3.1% of ${}^{30}\text{Si}$.

 _____ (4 marks)

2.5 Covalent bonding

1. The following gases exist as molecules. Draw dot-cross diagrams, showing outer electrons only, to represent the bonding in each of the following substances:

hydrogen gas (H ₂)	nitrogen (N ₂)
hydrogen sulfide (H ₂ S)	hydrogen chloride (HCl)

(8 marks)

2. Methane is used as a fuel and burns in oxygen to form carbon dioxide and water.
a. Draw a dot cross diagram of the following substances. Show outer shell electrons only.

methane	oxygen
carbon dioxide	water

(8)

- b. Write a balanced chemical equation for the burning of methane.

_____ (2)

- c. Covalent compounds with simple molecular structures have a low melting point and boiling. Explain why this is so.

_____ (1)

- d. State another physical property of covalent compounds.

_____ (1)

(12 marks)

2.6 Representing chemical reactions

1. Complete the following word equations:

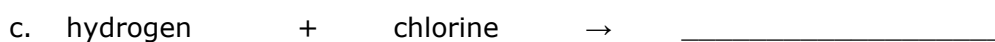

(5 marks)

2. Balance the following chemical equations



(8 marks)

3. For each of the following reactions, write a:

i. Word equation

ii. Balanced chemical equation. Include state symbols.

a. Methane burning in a plentiful supply of oxygen to form carbon dioxide and water.

i. _____ (1)

ii. _____ (3)

b. Methane burning in limited supply of oxygen to form carbon monoxide and water.

i. _____ (1)

ii. _____ (3)

(8 marks)

2.7 Diffusion and density of gases

1. Explain the following observations in terms of particles:
- a. When a bottle of perfume is opened, people in all parts of the room soon notice the smell. Use the ideas of diffusing particles to explain how this happens.

_____ (2)

- b. Bromine diffuses faster in an evacuated gas jar compared to a jar containing air.

_____ (2)

(4 marks)

2. The apparatus shown below was set up. Give explanations for the following observations.

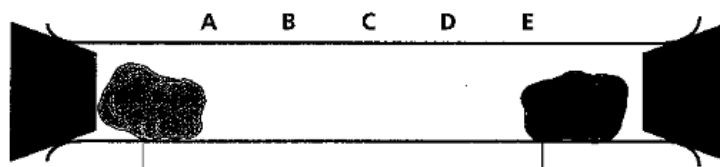

cotton wool soaked in
concentrated hydrochloric acid.

cotton wool soaked in
concentrated ammonia solution.

- a. At which point, A to E, along the tube will a white cloud be seen? Explain your answer in terms of the movement of particles.

_____ (2)

- b. Give the name to the white cloud formed.

_____ (1)

- c. It took a few minutes before the white cloud formed. Explain why this happened.

_____ (2)

- d. Cooling the ammonia and hydrochloric acid before carrying out the experiment increased the time taken for the white cloud to form. Explain.

_____ (2)

(7 marks)

2.8 Preparing, collecting, and testing for gases

1. The diagram shows the apparatus used to prepare oxygen gas in the laboratory. Two reagents are used to prepare oxygen gas. One of them is placed in the flat-bottomed flask and the other one is placed in the tap funnel.

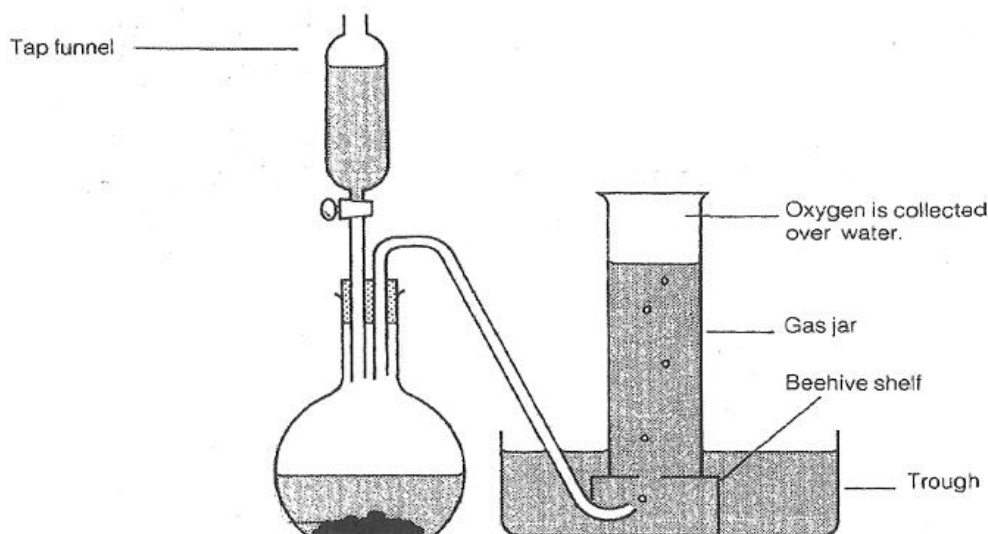

- a. i. Name the solution placed in the tap funnel.
 _____ (1)
- ii. Name the powder placed in the flat-bottomed flask.
 _____ (1)
- iii. What is the role of the powder in the flat-bottomed flask? Explain.

 _____ (2)
- iv. Write a balanced chemical equation to show the reaction that takes place.
 _____ (2)
- b. Oxygen is collected over water as shown in the diagram. Explain why this method is suitable to collect oxygen.
 _____ (1)
- c. Describe the test for oxygen and state the expected result.
 _____ (1)
- d. Give **two** uses of oxygen.
 _____ (2)

Question continues on the next page.

- e. Draw a labelled diagram to show how oxygen may be produced and collected in a different way.



(4)

(11 marks)

2. Gases may be collected using the methods shown in diagrams P, Q and R.

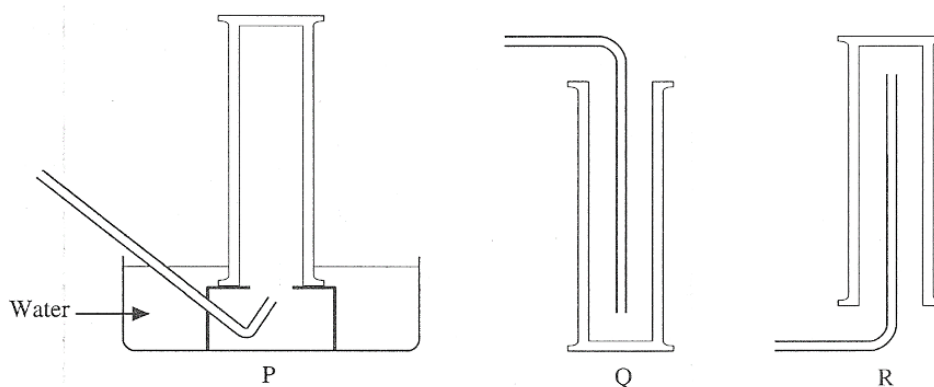

Using the letters P, Q, and R, give all the methods that can be used to collect each of the following gases.

- a. Oxygen: _____ (2)
- b. Carbon dioxide: _____ (2)
- c. Hydrogen: _____ (2)
- d. Give the name of the gas which:
- i. turns limewater milky: _____ (1)
- ii. relights a glowing splint: _____ (1)

(8 marks)

3. Carbon dioxide is a gas which is present in air.
- a. The diagram below shows the apparatus used to prepare carbon dioxide gas in the laboratory. Two reagents are used to prepare carbon dioxide gas. One of them is placed in the flat-bottomed flask and the other is placed in the thistle funnel.

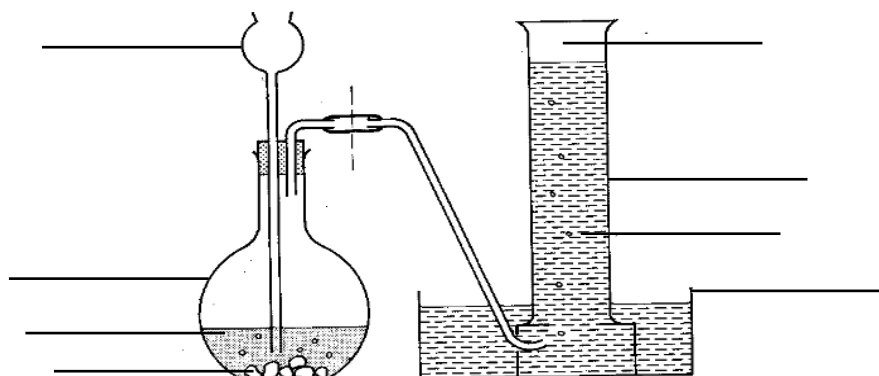

- i. Label the diagram above. (4)
- ii. Write a balanced chemical equation to show the reaction between these two reagents. (2)

_____ (2)

- iii. Draw a dot-cross diagram to show the bonding in carbon dioxide. Show outer shell electrons only. (2)

(2)

- iv. Explain why the thistle funnel is always dipped below the solution. (1)
- _____ (1)

- b. The method of collecting a gas depends on the density of the gas being collected, and its solubility in water.

- i. The diagram shows that carbon dioxide is collected 'over water'. Suggest one problem with collecting carbon dioxide this way. (1)

_____ (1)

- ii. Name a different method by which carbon dioxide can be collected and suggest why it is suitable for this gas. (1)

Method: _____ (1)

Suitability: _____ (1)

- c. Carbon dioxide can be used in fire extinguishers. Give a reason for this. (1)
- _____ (1)

(13 marks)

4. Dilute hydrochloric acid is added via thistle funnel onto zinc metal contained in a flat-bottomed flask. A reaction occurs forming hydrogen gas, H_2 . The gas is then collected by upward delivery.

Hydrogen burns in air (oxygen) to form a colourless liquid with a boiling point of $100\text{ }^\circ\text{C}$.

- a. Give the name of this colourless liquid. _____ (1)
- b. Draw a dot-cross diagram, showing outer electrons only to illustrate the bonding present in a molecule of this liquid and name the type of bond present between the atoms.

Name of bond: _____ (1)

(2)

- c. Write balanced chemical equation for the:
- i. reaction between zinc and dilute hydrochloric acid.
 _____ (2)
- ii. reaction when hydrogen burns in air (oxygen).
 _____ (2)
- d. Name the property of hydrogen which makes it possible to collect it by upward delivery.
 _____ (1)
- e. Describe the test for hydrogen and state its expected result.
 _____ (2)
- f. Give **two** uses for hydrogen.
- Use 1: _____ (1)
- Use 2: _____ (1)
- (12 marks)

2.9 Atmospheric pollution

1. Explain the following statements.

a. Air is a mixture of elements and compounds.

_____ (2)

b. Power stations burning coal are thought to be a major cause of acid rain.

_____ (2)
(4 marks)

2. Carbon dioxide and carbon monoxide are oxides of carbon.

a. Carbon dioxide is a greenhouse gas.

i. What do you understand by the term "greenhouse gas"?

_____ (1)

ii. Explain why the concentration of carbon dioxide in the atmosphere has increased over the past 100 years.

_____ (2)

iii. Mention **two** ways excess carbon dioxide in the atmosphere adversely affects our climate.

_____ (1)

iv. Name the natural process by which carbon dioxide is removed from the air.

_____ (1)

b. Carbon monoxide is an atmospheric pollutant.

i. Name a source of carbon monoxide and explain how it is formed.

_____ (2)

ii. State an adverse effect of carbon monoxide on health.

_____ (1)

(8 marks)

3. a. Name an air pollutant produced by the burning of coal.

_____ (1)

b. Name another air pollutant produced by the combustion of petrol in car engines.

_____ (1)
(2 marks)

4. a. Rainwater is naturally acidic. Explain.

_____ (2)

b. The gas which makes rain naturally acidic is different from those gases which give rise to acid rain.

i. Name the **two** gases which produce acid rain.

_____ (2)

ii. Name the acids which the gases in part b) i) form and which are responsible for acid rain.

_____ (2)

iii. Name **two** adverse effects of acid rain.

_____ (2)
(8 marks)

5. Oxides of nitrogen are pollutant gases found in the atmosphere. Cars and other vehicles are mainly responsible for the presence of these gases in the atmosphere.

a. Nitrogen and oxygen react inside a car engine to produce nitrogen monoxide gas. Give the **formula** of this gas.

_____ (1)

b. As it exits from the exhaust, the nitrogen monoxide produced in the car engine then reacts with oxygen from the air and forms a brown gas. Give the **name** and **formula** of this gas.

_____ (2)

c. This brown gas reacts with water from the atmosphere to produce an acid. Give the **name** and **formula** of the acid produced.

_____ (2)

d. Name a car part that can help eliminate the problem of pollution by oxides of nitrogen.

_____ (1)
(7 marks)

6. Sulfuric acid is one of the acids that is present in acid rain.

a. Give the pH range of acid rain.

_____ (1)

b. Sulfuric acid is formed due to the evolution of sulfur dioxide. Give a balanced chemical equation to show how sulfur dioxide is changed into sulfuric acid as it goes up in the air.

_____ (2)

c. The bar chart below shows the mass of sulfur dioxide emitted from Europe, United States and Asia in 1990, 2000, 2010 and 2020.

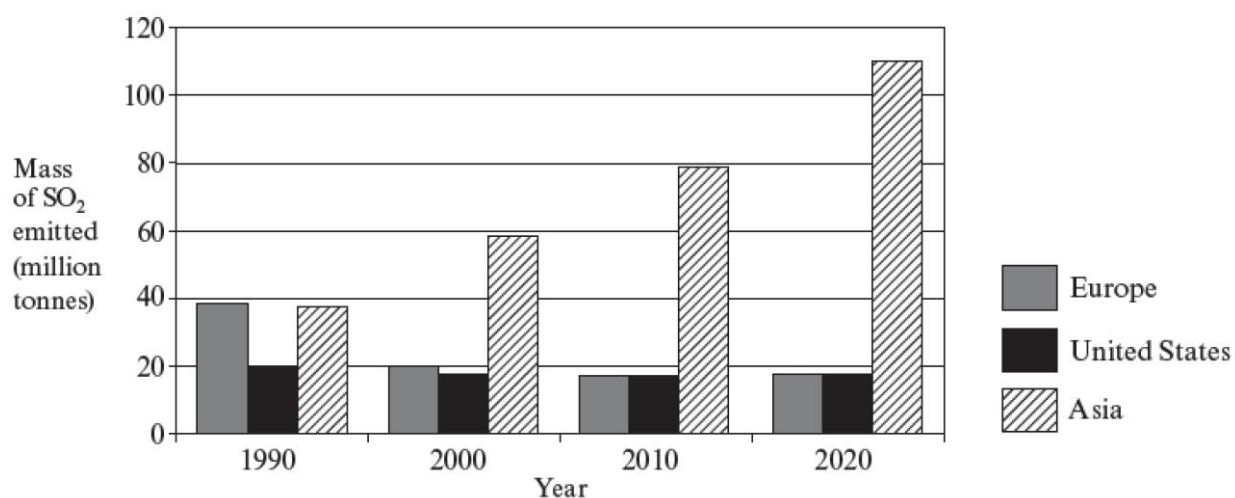

i. Use the graph to describe the trend in sulfur dioxide emission in Europe from 1990 to 2020.

_____ (1)

ii. Suggest one method to reduce emissions of sulfur dioxide in air.

_____ (1)

iii. Using the graph, estimate the increases in mass of sulfur dioxide emitted in million tonnes from 1990 to 2020 in Asia.

_____ (2)

iv. Suggest a reason why sulfur dioxide emissions in Asia are increasing over the years.

_____ (1)

v. Use the graph to describe the trend in sulfur dioxide emission in the United States.

_____ (1)

d. Cargo ships are known to emit sulfur dioxide. Research which fuel is used by cargo ships.

_____ (1)

(10 marks)

7. The graph below illustrates the size of the Antarctic ozone hole from 1979 to 2012. The Antarctic ozone hole has been observed each year for at least decades. The size of the ozone hole and the amount of ozone destroyed varies quite a bit from year to year because the atmospheric conditions in the Antarctic winter and early spring are different from year to year. The ozone hole area is measured by satellites.

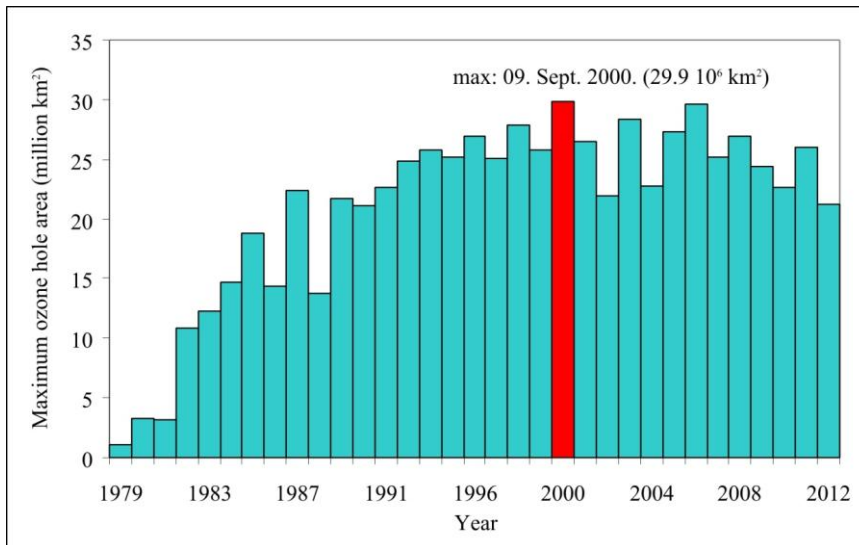

- a. Describe what causes ozone depletion in the stratosphere.
-
-
- (2)
- b. Explain how the depletion of ozone in the stratosphere impacts the Earth.
-
- (1)
- c. Describe the potential consequences of prolonged ozone depletion on human health, agriculture, and ecosystems.
-
-
- (3)
- d. Describe the measures and international agreements that have been put in place to mitigate ozone depletion and the progress made so far.
-
-
- (2)
- e. From graph describe the trend of the ozone hole area between 1979 and 1987.
-
- (1)
- f. From graph describe the trend of the ozone hole area between 2000 and 2012. Explain why you think this happened.
-
-
- (2)
- (11 marks)

3 The solvent action of water including the impact of water hardness (LO 3)

3.1 Water – a source of life and conflict

Water Wars: Understanding the Struggle for the World's Most Precious Resource

Water, a life-sustaining resource, is essential for all living beings on Earth. However, with increasing demands and dwindling supplies, conflicts over water have emerged in various regions worldwide. This passage aims to shed light on the concept of "Water Wars" and the challenges associated with securing and managing this precious resource.

Water wars refer to conflicts arising from the scarcity, distribution, and control of water resources. These conflicts can take various forms, ranging from local disputes between communities to interstate and international confrontations over shared water bodies.

Water wars are caused by water scarcity, unequal access to water and pollution. Growing populations, industrialization, and climate change contribute to the depletion of freshwater sources, leading to increased competition for available water. Often, water resources are not equally distributed, leading to disparities in access and further exacerbating tensions between regions or countries. Water pollution from industrial waste and agricultural runoff can lead to contamination of water sources, sparking conflicts over clean water. Moreover, building dams and other water-related infrastructure can impact downstream water flow, leading to disagreements between neighbouring communities or countries.

There are many disputes over water particularly in Africa due to water shortages. For example, (1) The Jordan River Dispute: Conflicts over the Jordan River's water resources have been ongoing between Israel, Jordan, and the Palestinian territories, affecting regional stability. (2) The Nile River Basin Conflict: Countries along the Nile have faced disputes over the equitable sharing of its waters, impacting Egypt, Sudan, Ethiopia, and other nations in the region.

Water shortages can lead to food insecurity, displacement, and heightened tensions, resulting in humanitarian crises. Over-extraction and pollution of water sources can damage ecosystems and threaten biodiversity. Water scarcity can hinder economic development and lead to higher costs for water-dependent industries like agriculture.

Water wars are a stark reminder of the critical role water plays in our lives and the necessity of managing this precious resource responsibly. By understanding the causes, consequences, and potential solutions to water conflicts, we can work together to ensure a sustainable and secure water future for all.

Read the above text and answer the following questions.

- a. What are "Water Wars"?

_____ (2)

- b. Name **three** factors that contribute to the causes of water wars.

_____ (3)

- c. Name **two** effects of water wars on communities and the environment.

_____ (2)

(7 marks)

3.2 Potable water sources in Malta

Malta is a small country, which has a semi-arid Mediterranean climate, characterized by a general lack of rainfall during the summer period. The island has no exploitable surface waters, and thus groundwater is the only natural water resource which is available all year round.

Groundwater resources in the island can be broadly divided into two main groupings, primarily based on the accessibility of the resource: the perched aquifers, which are mainly located in the western regions of the island, where groundwater is found in limited quantities but at shallow depths and in free flowing springs; and the sea level aquifers which whilst having a vastly greater exploitation potential than the perched aquifers are difficult to exploit due to the depth of the saturated zone. The main pumping station that extracts water from the sea level aquifer is at Ta' Kandja which is situated in the limits of Siġġiewi. This was dug by hand between the 1950-60s. It consists of a network of galleries that radiate like the spokes of a wheel for thousands of metres. For a long time, Malta used ground water as its source of potable water. However, the extraction of ground water to meet the demand of the rapid population increase was not enough and resulted in the deterioration of the status of the aquifers. The first reverse osmosis (RO) plant was built in 1982 in Għar Lapsi. Today there are four RO plants situated at Pembroke, Ċirkewwa, Għar Lapsi and Hondoq (Gozo). In an RO plant seawater is converted into high purity drinking water. In 2022 64% of potable water was obtained from the RO.

Potable water is chlorinated before it is distributed. On the recommendations of Sir Temi Żammit and Major A. H. Morris, sterilization via chlorination was initiated in 1909 thus rendering the public supply safer.

(Adapted from Sapiano, M., Micallef, P., Attard, G., & Żammit, M. L. (2008). The evolution of water culture in Malta: an analysis of the changing perceptions towards water throughout the ages and <https://www.wsc.com.mt/about-us/water-production-distribution/>)

1. Name **two** sources of potable water.

_____ (2)

2. Explain why it is necessary to chlorinate potable water.

_____ (1)

3. Suggest why the water quality obtained from ground water deteriorated over the years.

_____ (1)

4. Briefly explain how potable water is obtained at the reverse osmosis.

_____ (2)

5. Give a reason why the process of converting sea water to potable water is expensive.

_____ (1)

(7 marks)

3.3 Properties of pure water

- What type of oxide is water?
_____ (1)
- Write the formula of water using the correct symbols.
_____ (1)
- Give **three** physical properties that can be used to determine that a sample of colourless liquid is pure water.

_____ (3)
- Describe the test and expected result that is used to check whether a liquid is water.

_____ (2)
- Explain why water can be described as a universal solvent.

_____ (2)
- Give a reason why tap water is not considered to be pure water.
_____ (1)

3.4 Mixtures

- What is the difference between a homogenous and a heterogenous mixture?

_____ (2)
 - Classify each of the following as a homogenous or heterogenous mixture:
 - Rock salt _____ (1)
 - Chalk and water _____ (1)
 - Sand and water _____ (1)
 - Air _____ (1)
 - Ethanol and water _____ (1)
- (5 marks)

3. Give an example of:

- a. a solute _____ (1)
- b. an insoluble substance _____ (1)
- c. a solution _____ (1)
- d. a suspension _____ (1)
- e. a solvent _____ (1)
- (5 marks)

3.5 Obtaining table salt

1. Salt is a very important raw material for the chemical industry.

a. In hot countries such as those in the Mediterranean, salt is obtained from sea water after it is placed in salt pans.

i. Describe how salt forms in salt pans.

_____ (1)

ii. Course salt is generally obtained from salt pans rather than fine salt. Explain.

_____ (1)

b. In other countries the main source of salt is rock salt which is found in large underground deposits. One method of removing rock salt is shown in the diagram below. This is known as solution mining. Water is pumped down at 150 °C and at very high pressure. The resulting salt solution (brine) is forced to the surface from which then sodium chloride would be obtained.

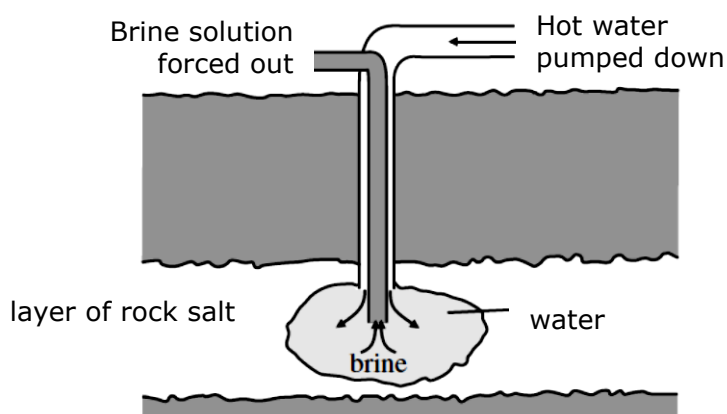

i. Rock salt is known to be a mixture. Explain.

_____ (1)

ii. Explain the purpose of pumping hot water into the underground rock salt deposit.

_____ (2)

iii. Brine is concentrated salt solution. What is meant by the term concentrated solution?

_____ (1)

iv. Give one use of salt in the industry.

_____ (1)

c. You are given a sample of rock salt. Draw a labelled diagram to show the 3 main steps required to obtain salt from rock salt in the lab. For each stage write a short description to explain the purpose of each step in the experiment.

	Labelled Diagram	Description
Stage 1		
Stage 2		
Stage 3		

(9)

(16 marks)

3.6 Salts and ionic bonding

1. Atoms are neutral because they have an equal number of protons and electrons. When atoms lose or gain electrons, ions are formed.

a. Complete the following statements:

When metal atoms lose their outermost electrons, they become _____ charged ions. When non-metals gain electrons to have a complete outer shell they become _____ charged ions. The attraction between oppositely charged ions is known as the _____ bond. (3)

b. The table shows some information about atoms and ions.

i. Complete the following table:

Particle	Mass number	Number of protons	Number of neutrons	Number of electrons	Electronic configuration
Li atom		3	4		
Li ⁺ ion					
F ⁻ ion	19	9			
Ne atom			10	10	
S ²⁻ ion	32			18	

(17)

ii. Which particles in the table above, apart from the neon atom have the same total number of electrons as a noble gas?

_____ (2)

iii. Mg²⁺ ion is a positively charged ion. Write its electronic configuration and explain why it is a 2+ ion.

_____ (2)

(24 marks)

2. Sodium is a metal in Group 1 while fluorine is a halogen in Group 7.

Complete the following passage.

Sodium and fluorine combine to form sodium _____. When this happens, each sodium atom gives an _____ to a fluorine atom. Sodium ions with a _____ charge and fluoride ions with a _____ charge are formed. The _____ ions and the _____ ions are held together by strong _____ forces of attraction. This attraction forms a chemical _____. This type of chemical bond is called the _____ bond. The resulting formula of the compound is _____. (10 marks)

3. a. From the diagrams below, identify one that represents the giant ionic structure of sodium chloride.

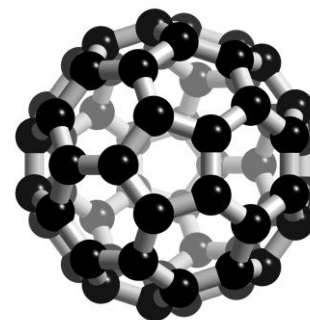
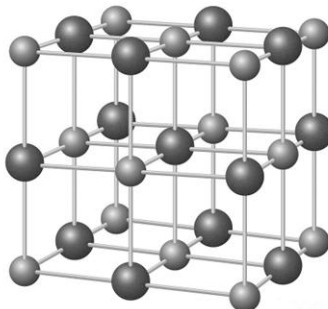

(1)

- b. Sodium chloride has a relatively high melting point (801 °C). Explain this fact using your knowledge of ionic bonding.

(2)

- c. List **two** other properties of ionic substances.

(2)

(5 marks)

4. Lithium has atomic number 3 and chlorine has atomic number 17. Draw a dot and cross diagram showing the bonding in lithium chloride. Show all electron shells.

(3)

5. Draw a dot and cross diagram of the bonding present in: Show all electron shells.

a. magnesium oxide, MgO

(3)

b. sodium oxide, Na₂O

(3)

c. magnesium chloride, MgCl₂

(3)

d. aluminium fluoride AlF₃

(3)

(12 marks)

6. Name the following compounds.

SUBSTANCE	NAME
LiBr	
AlCl ₃	
K ₂ O	
MgF ₂	
MgS	
KBr	

(6 marks)

7. Write the chemical formulae of the following compounds.

- a. potassium fluoride _____
- b. magnesium oxide _____
- c. calcium bromide _____
- d. barium chloride _____
- e. sodium iodide _____
- f. aluminium oxide _____

(6 marks)

8. Name the following compounds.

SUBSTANCE	NAME
FeO	
Cu ₂ O	
AgCl	
PbI ₂	
CuS	
ZnBr ₂	
MnO ₂	
FeBr ₃	
FeCl ₂	
PbO	

(10 marks)

9. Name the following compounds.

SUBSTANCE	NAME
KNO_3	
NaHCO_3	
Mg(OH)_2	
ZnSO_3	
BaSO_4	
LiNO_2	
CuCO_3	
$(\text{NH}_4)_3\text{PO}_4$	
$\text{Fe}_2(\text{SO}_4)_3$	
$\text{Zn(NO}_3)_2$	
AgS	
SrSO_3	
Pb(OH)_2	
NH_4NO_3	
$\text{Ca(HCO}_3)_2$	

(15 marks)

10. Write the chemical formulae of the following compounds.

- ammonium chloride _____
- copper(II) hydroxide _____
- lead(II) nitrate _____
- barium chloride _____
- magnesium hydrogen carbonate _____
- sodium sulfite _____
- copper(I) sulfate _____
- iron(III) oxide _____
- copper(I) sulfide _____
- iron(II) hydroxide _____

(10 marks)

11. Convert these word equations into balanced chemical equations.

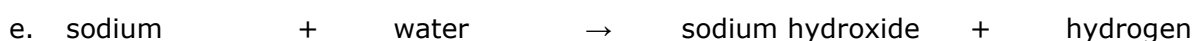

(12 marks)

12. Balance the following chemical equations

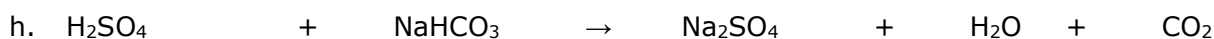
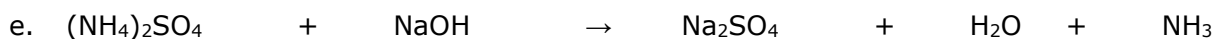
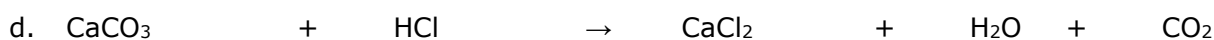

(14 marks)

13. For each of the following reactions, write a:

i. Word equation

ii. Balanced chemical equation. Include state symbols.

a. A solution of potassium iodide reacts with lead(II) nitrate solution to produce a yellow solid of lead(II) iodide and potassium nitrate solution.

i. _____ (1)

ii. _____ (3)

b. Hydrochloric acid (HCl) reacts with magnesium ribbon to produce hydrogen gas and magnesium chloride solution.

i. _____ (1)

ii. _____ (3)

c. Phosphoric acid (H_3PO_4) reacts with calcium carbonate powder to produce a solution of calcium phosphate, carbon dioxide and water.

i. _____ (1)

ii. _____ (3)

d. Sulfuric acid (H_2SO_4) reacts with sodium hydroxide solution to produce sodium sulfate solution and water.

i. _____ (1)

ii. _____ (3)

e. Ammonium sulfate solution reacts with potassium hydroxide solution to produce ammonia gas, potassium sulfate solution and water.

i. _____ (1)

ii. _____ (3)

(20 marks)

3.7 Solvent action of water, solution, and solubility

1. Most substances dissolve in water.

a. Give the definition of solubility.

_____ (1)

b. Give **three** factors that affect the rate at which a substance dissolves in a solvent.

_____ (3)
(4 marks)

2. Classify the following substances as soluble or insoluble by placing a (✓) under the correct heading:

Substance	Soluble	Insoluble
sodium carbonate		
silver nitrate		
copper(II) oxide		
calcium nitrate		
sodium hydroxide		
sodium sulfate		
copper(II) nitrate		
sodium hydrogencarbonate		
potassium chloride		
ammonium hydroxide		
calcium chloride		
silver chloride		
magnesium carbonate		

(13 marks)

3. The graph below shows how the solubility of four different substances changes with temperature. Solubility is measured in g/100 g H₂O.

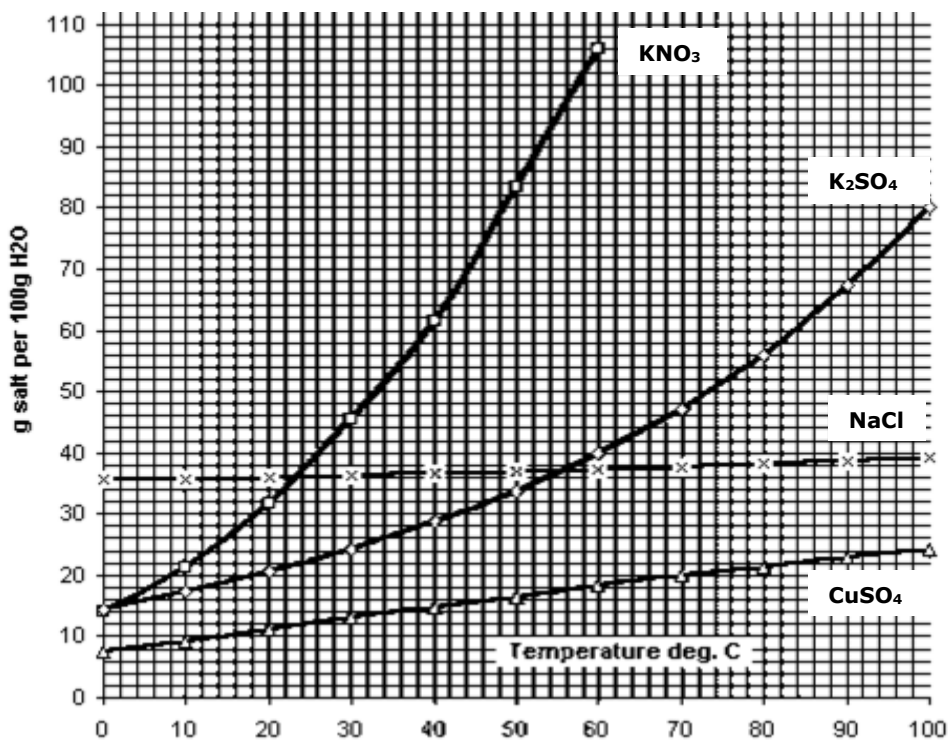

- a. State the solubility of KNO₃ at 40 °C. _____ (1)
- b. Which substance has the greatest solubility at standard temperature (0 °C)?
 _____ (1)
- c. What can you say about the solubility of NaCl as temperature increases?
 _____ (1)
- d. Compare the solubility of KNO₃ and CuSO₄.

 _____ (2)
- e. What is the solubility of NaCl in 50 g of water at 80 °C?
 _____ (2)
- f. Calculate the mass of copper(II) sulfate that would crystallise if the solution cooled from 60 to 10 °C.

 _____ (2)
- g. Describe how the solubility of a gas changes on increasing temperature.
 _____ (1)

(10 marks)

3.8 Hard and soft water

1. State whether the following statements are true or false.
 - a. Water that passes over limestone can become hard. _____
 - b. Water can be softened by adding chlorine to it. _____
 - c. Scale is formed when soap is added to hard water. _____
 - d. The use of washing soda removes all types of hardness. _____
 - e. Boiling is a method that can remove permanent hardness. _____
 - f. Less soap is used to form a lather with hard water. _____
 - g. Hard water can cause the build-up of scale in boilers. _____

(7 marks)

2. Dissolved ions found in water can cause the build-up of scale on the heating elements of boilers and electric kettles.

- a. Explain why the accumulation of scale causes a problem in kettles.

_____ (1)

- b. Write a balanced chemical equation to show the formation of scale inside a kettle.

_____ (2)

- c. Give **two** benefits of hard water.

_____ (2)

(5 marks)

3. In an experiment to compare the hardness of different water sources, soap solution was added to samples of water using a burette. The soap was added dropwise until a lather was formed. The samples of water were boiled, and the experiment was repeated. The table below shows the results of this experiment.

Source	Drops of soap solution needed to produce a lather using unboiled sample.	Drops of soap solution needed to produce a lather using boiled sample.
A	5	5
B	24	12
C	30	5
D	28	28

Write the correct letters in the spaces below:

- a. Source _____ is soft water. (1)
- b. Source _____ contains both temporary and permanent hardness. (1)
- c. Source _____ only contains only temporary hardness. (1)
- d. Source _____ only contains permanent hardness. (1)

(4 marks)

4. Samples of water were collected from different locations and tested with a soap solution to see how much soap was needed to form a lather. The experiment was repeated a second time using water that was boiled and then a third time using water that was passed through an ion exchanger. The results below show the volume of soap needed to form a lather with 25 cm³ samples of water.

Location	Volume of soap needed in cm ³		
	Untreated Water	Boiled Water	Water passed through ion exchanger
Attard	25	18	1.5
Rabat	22	1.5	1.5
Cirkewwa	1.5	1.5	1.5
Sliema	16	16	1.5

- a. Which sample of water is the hardest? Give a reason for your answer.

 _____ (2)
- b. Which sample of water came from a reverse osmosis plant? Give a reason for your answer.

 _____ (2)
- c. Which sample of water contains:
- i. Both permanent and temporary hardness _____ (1)
- ii. Only permanent hardness _____ (1)
- iii. Only temporary hardness _____ (1)
- d. Name a substance that could possibly be found in the sample of water taken from Sliema.
 _____ (1)
- e. Name a substance that could possibly be found in the sample of water taken from Rabat.
 _____ (1)
- f. Write a balanced chemical equation for the reaction of soap with water taken from Attard.
 _____ (1)
- g. Describe how the ion-exchanger works.

 _____ (2)

(15 marks)

5. A group of students collected a sample of sea water from Baħar iċ-Ċagħaq and decided to carry out a number of tests on it in the school laboratory.
- a. They first had a discussion on the boiling point of the sample. Anabel said that the boiling point would be 100 °C, Jeremy said that it would be more than 100 °C while Bettina said that the boiling point would be less than 100 °C. With whom do you agree? Give a reason for your answer.

_____ (2)

- b. Draw and label the apparatus that could be used in the laboratory to obtain a sample of pure water from sea water by distillation.

(5)

- c. In Malta, potable water is obtained by reverse osmosis rather than by distillation of sea water. Discuss.

_____ (2)

- d. Briefly describe the steps involved in reverse osmosis.

_____ (3)
(12 marks)

4 Acids, bases, and salts (LO 4)

4.1 Indicators

1. A pH probe can be used to get an accurate reading from different liquids. Different solutions were tested. The results are shown in the table below.



a. Put a tick mark (✓) in the correct box to show whether the solution was acidic, alkaline, or neutral.

Solution	pH Reading	Acidic	Alkaline	Neutral
Tomato juice	4.4			
Blood	7.4			
Toothpaste	9.9			
Lemon Juice	2.2			
Pure water	7.0			

(5)

b. Between each test, the probe should be rinsed with pure water. Suggest a reason for this.

_____ (1)

c. Indicators are commonly used to determine the pH of solutions.

i. Briefly explain the term indicator.

_____ (1)

ii. Give **two** examples of an indicator.

_____ (2)

c. Describe how the pH of lemon juice could be found using universal indicator solution.

_____ (2)

d. Give **two** reasons why it is more desirable to use a pH probe rather than universal indicator to determine the pH of blood.

_____ (2)

(10 marks)

4.2 Acids

1. Sulfuric acid and ethanoic acid are two examples of acids, but ethanoic acid is a weak acid.
- a. Explain what is meant by a weak acid.
- _____ (1)
- b. Suggest an approximate pH for:
sulfuric acid _____ ethanoic acid _____ (2)
- c. Write an equation for the ionisation of sulfuric acid.
- _____ (2)
- d. A piece of magnesium ribbon is added to the 10cm³ of sulfuric acid. At the same time another piece of the same length of magnesium ribbon is added to 10 cm³ ethanoic respectively. Effervescence is produced in both reactions.
- i. Which variable was varied in this experiment?
- _____ (1)
- ii. List the controlled variables in this experiment.
- _____ (3)
- iii. Explain why more effervescence was given in the reaction between magnesium and sulfuric acid than with ethanoic acid.
- _____ (2)
- iv. Describe a test for the gas produced and state the expected result.
- _____ (2)
- v. Write a balanced chemical equation for the reaction of:
- Sulfuric acid with magnesium.
- _____ (2)
- Ethanoic acid with magnesium.
- _____ (2)

(16 marks)

4.3 Bases and alkalis

1. Potassium hydroxide is an alkali and iron(II) hydroxide is a base.

a. Explain the difference between an alkali and a base.

_____ (2)

b. Potassium hydroxide is known to be strong alkali. Explain what this means.

_____ (2)

c. The following hazard symbols are on the bottle of potassium hydroxide. Explain what the symbols mean.



_____ (2)

d. Ammonium nitrate is heated with potassium hydroxide.

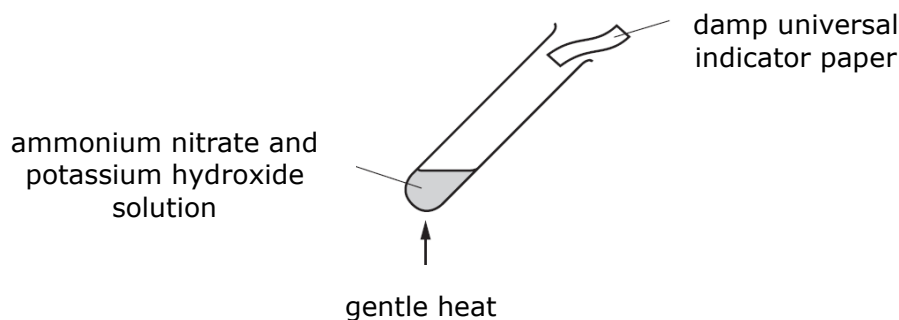

i. Fill in the blanks by completing the following paragraph.

On heating, a gas is evolved, and the damp universal indicator paper turns blue. When compared to the pH chart the gas has a pH of 9. This shows that the gas is weakly _____. This means that it _____ ionises in water realising only a _____ ions. (4)

ii. Describe another test to identify the gas evolved.

_____ (1)

iii. Write a balanced chemical equation for the reaction between ammonium nitrate and potassium hydroxide solution.

_____ (2)

(13 marks)

4.4 Metallic and non-metallic oxides

1. Classify which of the following oxides are basic, acidic, neutral, or amphoteric.

H₂O CO₂ SO₂ K₂O PbO CO
 FeO ZnO NO₂ Al₂O₃ NO CaO

Acidic oxides	Basic oxides	Neutral oxides	Amphoteric oxides

(9 marks)

2. A student tests the nature of some oxides by carrying out the following experiments.

a. Carbon dioxide is bubbled through water. The resulting solution is tested with red and blue litmus paper.

i. Describe the results observed when using red and blue litmus paper.

_____ (2)

ii. Name the product formed as carbon dioxide reacts with water.

_____ (1)

b. Calcium oxide is added to water. The resulting solution is tested with blue and red litmus paper.

i. Write a balanced chemical equation for this reaction.

_____ (2)

ii. Describe the results observed when using red and blue litmus paper.

_____ (2)

c. Copper(II) oxide is a base

i. Explain why litmus paper cannot be used to determine that copper(II) oxide is a base.

_____ (1)

ii. Describe a test to show that copper(II) oxide has basic properties.

_____ (2)

d. Aluminium oxide is classified as an amphoteric oxide. Explain what this means.

_____ (1)

(11 marks)

4.5 Acid reactions

1. Complete the following reactions involving acids and balance the chemical equations:



(16 marks)

2. This question is about the reactions of acids. Fill in the missing spaces in the table below.

Method of preparation	Reactants	Salt Formed	Other Products
acid + alkali	sodium hydroxide and hydrochloric acid
acid + metal	magnesium and sulfuric acid
acid + alkali and calcium hydroxide	calcium chloride
acid + carbonate and.....	sodium chloride	water and
acid + metal and.....	iron(II) sulfate
acid +	sulfuric acid and potassium hydroxide
acid + and.....	copper(II) sulfate	carbon dioxide and

(19 marks)

3. Magnesium sulfate (MgSO_4) is the chemical formula for Epsom salts. This salt can be made in the laboratory using common chemicals such as the base magnesium oxide (MgO) and an acid.

a. Name the acid that should be used in this neutralisation reaction.

_____ (1)

b. This acid is a strong acid. Explain what this means.

_____ (2)

c. Name the ion that is responsible for causing the 'acidity' in an acid.

_____ (1)

d. Write a balanced chemical equation for this reaction. Include state symbols.

_____ (3)

e. Name the type of reaction taking place in part (d).

_____ (1)

(8 marks)

4. When excess zinc is added to dilute sulfuric acid, hydrogen gas and a zinc compound are formed.

a. Give the balanced chemical equation for this reaction.

_____ (2)

b. When zinc was added to sulfuric acid the test tube got warmer. What does this indicate about the chemical reaction?

_____ (1)

c. Give **two** other observations for this reaction.

_____ (2)

d. Describe a test including the expected result to confirm that the gas formed is hydrogen.

_____ (2)

e. Give a reason why zinc was added in excess.

_____ (1)

f. The excess zinc was removed from the test tube, leaving behind a clear solution of zinc sulfate. Barium chloride solution was then added to the zinc sulfate solution. Give a balanced chemical equation for this reaction, including state symbols.

_____ (3)

(11 marks)

4.6 Applications of acid-base concepts in real-life situations

1. A student collected a sample of soil from a nearby field. She added 25 cm³ of water to the soil sample and shook it for a few minutes. The resulting solution was filtered to remove the solid particles. The pupil measured the pH of the filtrate using Universal indicator paper, then added ammonia solution to the filtrate. She recorded the pH during the addition of the aqueous ammonia. The student drew the following graph.

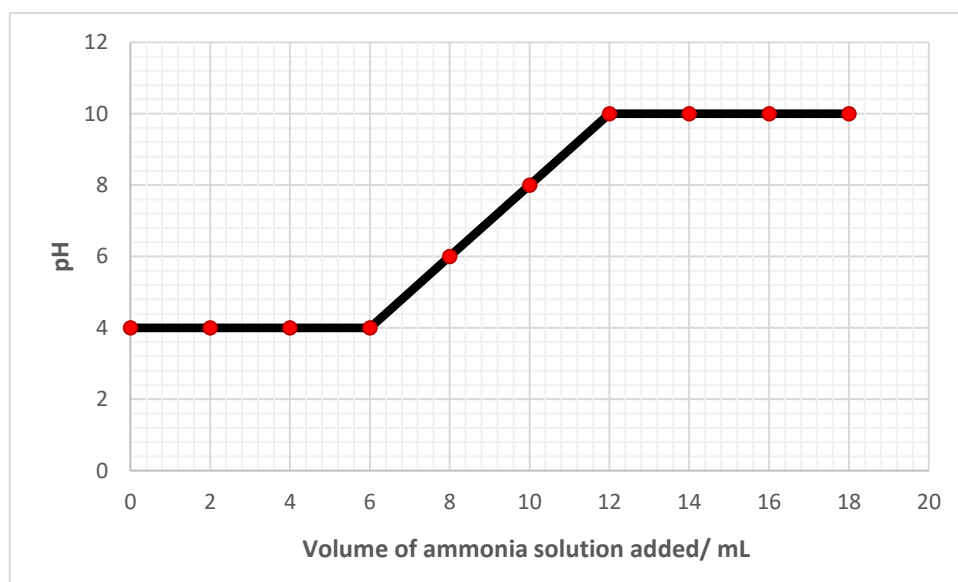

Use the graph to answer the following questions.

- a. What is the pH of the soil at the start of the experiment?

_____ (1)

- b. What does this tell you about the soil?

_____ (1)

- c. What is the pH value of the ammonia solution?

_____ (1)

- d. What volume of ammonia solution was added to make the soil neutral?

_____ (1)

- e. Ammonia is considered to be a weak alkali. Explain.

_____ (1)

(5 marks)

2. Sodium sulfate is used in washing powders. It can be produced in the lab by adding acid to an alkali.

a. Give the name of the acid and alkali to produce sodium sulfate.

_____ (2)

b. Write a balanced chemical equation for this reaction.

_____ (2)

c. Name the type of reaction taking place in part (b).

_____ (1)

d. Briefly describe the steps required to produce sodium sulfate crystals using an acid and alkali.

 _____ (6)

e. The table below shows the chemical composition of two washing powders A and B.

Washing powder	Percentage composition of washing powders				
	sodium sulfate	sodium carbonate	sodium silicate	soap	detergent
A	29	20	20	0	15
B	35	0	26	6	13

Dilute nitric acid was added to each of the powders. Only one of the powders reacted.

i. Which powder reaction with dilute nitric acid? Explain.

_____ (1)

ii. Give **one** observation noted in the reaction between the powder mentioned in part (e) (i) and dilute nitric acid.

_____ (1)

(14 marks)

3. Antacids tablets are taken when the stomach produces excess hydrochloric acid and causes stomach-ache. The following table shows the main ingredient found in two packets of antacid tablets.

Antacid tablets	Main ingredient
Packet 1	calcium carbonate
Packet 2	aluminium hydroxide

- a. Write a balanced chemical equation to show how stomach acid is neutralised with the tablet containing calcium carbonate.
_____ (2)
- b. Give an observation noted when the calcium carbonate is added to an acid.
_____ (1)
- c. Write a balanced chemical equation to show how stomach acid is neutralised with the tablet containing aluminium hydroxide.
_____ (2)
- d. Aluminium hydroxide is a base, but it is not an alkali. Explain why this is so.
_____ (2)
- e. Suggest why antacid tablets contain chemicals such as calcium carbonate or aluminium hydroxide but not sodium hydroxide.
_____ (2)
- f. Matthew and Sarah wanted to find out which is the most efficient tablet to neutralise stomach acidity. They first reacted each tablet with excess acid. Then they found out how much acid was left unreacted by reacting it with sodium hydroxide solution using a titration. They wrote the following method in their notebooks:

Crush a tablet using the pestle and mortar.
Place 2 g of the powdered tablet into a clean beaker.
Add excess hydrochloric acid (e.g. 100 cm³ of 1 mol dm⁻³) to each tablet making sure it dissolves completely.
Pour the acidic solution in a conical flask and add methyl orange indicator.
Add sodium hydroxide solution from a burette to the acidic solution until the indicator changes colour.
Record the volume of sodium hydroxide added.
Repeat the experiment with the second tablet.

- i. Explain why each tablet was crushed using a pestle and mortar rather than using a whole tablet in the experiment.
_____ (2)

- ii. Give **two** precautions the students took to ensure fair testing.

_____ (2)

- iii. Explain why excess acid was added to each tablet.

_____ (2)

- iv. Give the colour of methyl orange when it is added to an acidic solution.

_____ (1)

- v. Draw a labelled diagram of the setup used during titration.

(4)

- vi. The students obtained the following results from the experiment:

Antacid tablets	Main ingredient	Volume of sodium hydroxide (cm³)
Packet 1	calcium carbonate	60
Packet 2	aluminium hydroxide	25

Determine which tablet reacted with most acid.

_____ (1)

- vii. Explain why a titration of hydrochloric acid and a solution of each tablet could not be carried out.

_____ (2)

(23 marks)

4. Ammonium sulfate is an important fertiliser. It is made by reacting sulfuric acid with ammonia solution.

a. Give the approximate pH of sulfuric acid. _____ (1)

b. Sulfuric acid is a strong acid. Explain and support your answer with an equation.

 _____ (2)

c. Ammonia is a weak alkali. Explain and support your answer with an equation.

 _____ (2)

d. Write a balanced chemical equation for the reaction of sulfuric acid and ammonia solution.

_____ (2)

e. A farmer wanted to find out whether ammonium sulfate would be washed out of soil by rain and carried out the experiment shown in the diagram below.

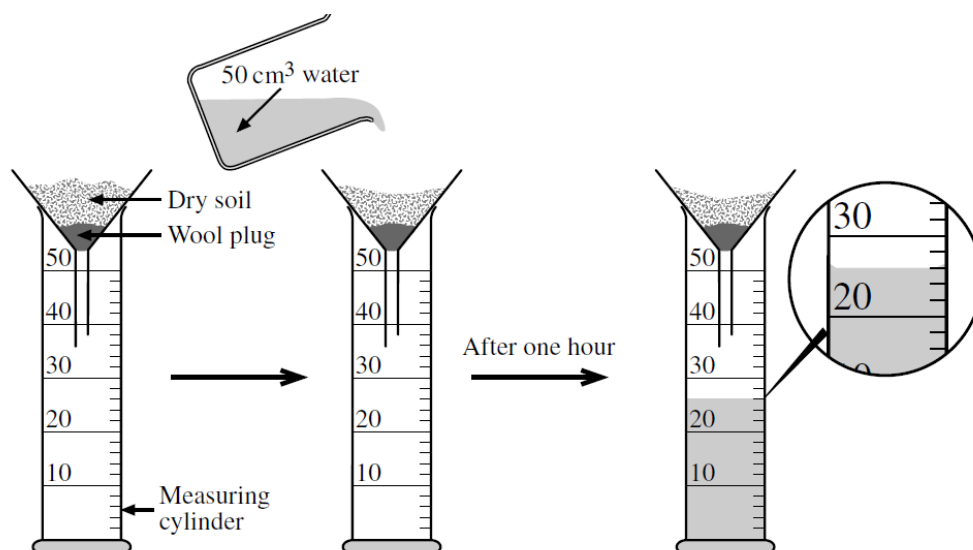

i. How much water has run through the soil after one hour? _____ (1)

ii. Describe how you would find the pH of water that has run through the soil.

 _____ (2)

iii. Sodium hydroxide solution was added to a solution of soil water and heated. A pungent smelling gas that turned damp red litmus paper blue was evolved. What can you conclude from this test? Support your answer with a balanced chemical equation.

 _____ (3)

(13 marks)

5. Copper metal is used for roofing in countries like Czech Republic. On exposure to the atmosphere the salmon pink copper metal progressively darkens and then forms a green patina. This is because copper reacts with oxygen to form copper(II) oxide and then it reacts with carbon dioxide to form the green patina.

a. Write a balanced chemical equation for the reaction of copper and oxygen.

_____ (2)

b. Write a balanced chemical equation for the reaction of copper(II) oxide and carbon dioxide.

_____ (2)

c. Give the chemical name of the green patina formed over copper.

_____ (1)

d. What type of reaction takes place in (b). Explain your answer.

_____ (2)

e. Suggest a method to remove the layer green patina from copper. Support your answer with a balanced chemical equation.

_____ (3)

(10 marks)

6. Calcium nitrate and calcium chloride are compounds often used in commercial treatment for garden plants. Each salt may be prepared by the reaction of a base and an acid.

a. Complete the table below by filling in with suitable reagents.

Base	Acid	Salt	Other products
		calcium nitrate	water
		calcium chloride	water carbon dioxide

(4)

b. Write a balanced chemical equation for the preparation of calcium nitrate.

_____ (2)

c. Write a balanced chemical equation for the preparation of calcium chloride.

_____ (2)

d. Calcium chloride can be prepared from calcium nitrate using two step reaction. Suggest **two** chemical reactions that can be used.

Chemical reaction 1: _____ (1)

Chemical reaction 2: _____ (1)

(10 marks)

4.7 Salts

1. Categorise the following compounds as soluble or insoluble by marking with a tick (✓).

Compound	Soluble	Insoluble
Sodium chloride		
Zinc nitrate		
Calcium carbonate		
Magnesium nitrate		
Nickel(II) carbonate		
Sodium phosphate		
Ammonium chloride		
Potassium dichromate		
Calcium sulfate		
Silver chloride		
Ammonium nitrate		
Iron(III) sulfate		

(12 marks)

2. a. Suggest solutions that could be mixed together to make each of the following insoluble salts. Include a balanced chemical equation, including state symbols.

- i. Silver chloride

Solutions: _____ (2)

Equation: _____ (2)

- ii. Calcium carbonate

Solutions: _____ (2)

Equation: _____ (2)

- iii. Lead(II) sulfate

Solutions: _____ (2)

Equation: _____ (2)

- iv. Magnesium hydroxide

Solutions: _____ (2)

Equation: _____ (2)

Question continues on next page.

- b. Describe how a pure, dry insoluble salt can be obtained from any of the mixtures mentioned above.

(4)
(20 marks)

3. Copper(II) sulfate can be prepared using copper(II) carbonate and dilute sulfuric acid.

- a. Give a balanced chemical equation for the reaction, including state symbols.

(3)

- b. State the colour change that is observed during this reaction.

(2)

- c. Apart from the colour change, what else can be observed during this reaction?

(1)

- d. As a precaution, excess copper(II) carbonate was added. Suggest a reason for this.

(1)

- e. Describe how excess copper(II) carbonate be removed after the reaction is over.

(1)

- f. Describe how the hydrated copper(II) sulfate crystals can be obtained from its solution. Include a labelled diagram.

(3)

(3)
(14 marks)

5 Physical and chemical changes (LO 9)

5.1 Distinguishing between physical and chemical changes

1.
 - a. Read the following passage and answer the questions beneath.

The Covid-19 pandemic has increased investing in gold. This element is mined and found in its native state. Gold is in hot demand as an investment, a status symbol, and a key component in many electronic products. But it's also a finite resource, and there will eventually come a stage when there is none left to be mined. Price rises have been driven by the pandemic as investors view gold as a safer asset in times of economic uncertainty. While gold in the ground may be hard to quantify, it's not the only source. There is also gold on the moon. However, the costs associated with mining it and transporting it back to earth are significantly higher than the value of the gold. A large amount of gold is used in electronic products that are widely viewed as disposable, such as mobile phones. The amount of gold in the average phone is worth a few pounds. Efforts to recycle gold extracted from electronic waste are already well under way.

<https://www.bbc.com/news/business-54230737>

- i. List THREE main uses of gold in its native state.

(3)

- ii. List TWO benefits of recycling gold other than mining it.

(2)

- iii. Explain why gold is found in its native state and not reacted with other non-metals to form compounds.

(2)

- b. On the other hand, the element calcium is rarely found in its native state. Complete the table below by filling in the spaces related to the different compounds of calcium and their uses.

Compound Name	Chemical formula	Common name	Use
Calcium carbonate		Limestone	
	CaSO ₄	Chalk	
		Marble	Buildings, stairs, statues.
		Quicklime	Water softeners, air purifiers, treat acidic soils.
Calcium hydroxide			
	CaSO ₄	Gypsum	

(13)

(20 marks)

2. State if these statements are true or false giving a reason for your answer (chemical equations should be used where necessary).

- The conversion of hydrated copper(II) sulfate into anhydrous copper(II) sulfate is a physical reaction as it is a reversible reaction.

True/false: _____ (1)

Reason:

 _____ (1)

- When a pink wall is painted green a chemical change takes place as this is accompanied by a change in colour.

True/false: _____ (1)

Reason:

 _____ (1)

- When potatoes are cut into chips a chemical reaction takes place as the process is irreversible.

True/false: _____ (1)

Reason:

 _____ (1)

(6 marks)

3. State if the following processes are physical or chemical changes.

Process	Physical/chemical
Two chemicals are mixed, and a gas is produced.	
Mixing salt and pepper in water.	
Toasting a marshmallow on a campfire.	
Autumn leaves changing colour.	
Dissolving copper(II) sulfate in water.	
Chocolate blocks changing into molten chocolate when heating on a flame.	
Magnesium pellets crushed into magnesium powder.	
A bicycle changes colour as it rusts when exposed to air and humidity.	
Paper towel absorbing water.	
Wood rotting.	

(10 marks)

4. Joel wrote this explanation in his discussion for a lab report titled 'The differences between mixtures and compounds':

When the black iron and the yellow powdered sulfur are mixed a physical change takes place as a mixture forms. However, when this mixture is heated using a Bunsen burner a new colour change is seen as a red glow is observed before the new compound forms a black colour. Using a magnet and reactions with hydrochloric acid one can prove that producing a mixture is a physical change and the new compound, iron(II) sulfide is the result of a chemical change.

a. Write a chemical equation, using state symbols, for the reaction between iron and sulfur.

_____ (2)

b. Fill in the table below listing the observations that would be noted by Joel in the lab.

Sample	Colour	Magnet (Is it magnetic?)	With hydrochloric acid (observations)
Iron (Fe)			
Sulfur (S)			
Iron and sulfur mixture	Greyish/yellow		
Iron (II) sulfide compound produced			Produces a toxic gas the smell of rotten eggs. This gas is hydrogen sulfide.

(10)

(12 marks)

5.2 The three states of matter and 1.3 Changes of state

1. Fill in the following paragraphs related to the three states of matter using suitable words or phrases.
- a. Particles in a solid are arranged _____ together and cannot move around. They can only _____ in fixed positions. This is why solids have a _____ shape and a _____ volume. The _____ are strongly attracted to each other with very _____ space in between. Thus it is very difficult to _____ them. (7)
- b. Particles in the liquid state have enough space between them so they can move around by rolling _____ each other. They can be poured from one _____ to another. The particles are _____ attracted to each other than in solids. A liquid can _____ shape and take the shape of any _____ they are in. However, they still have a _____ volume. The liquid particles are still arranged close together, and so it is _____ to compress them. (7)
- c. The particles in a gas are arranged very _____ apart from each other. This means that they can move about at a _____ speed. The particles in a gas spread out in all directions to _____ the space in a container. The space between the particles is very big and thus it is _____ to compress a gas. Many gases are invisible but they still have _____. (5)

(19 marks)

- 2.
- a. Molly took an aluminium can filled with lemonade out of the refrigerator in a hot summer day. Soon drops of liquid were seen trickling down the sides of the can. Molly started complaining that the can was damaged, and lemonade was trickling down the sides ruining her dress. However, Jacob explained this was not so. In the space provided, write what Jacob would have said to Molly.



(3)

- b. Jane poured 5 ml of sodium sulfate solution in a conical flask and 5 ml of barium chloride in a test tube, securing the test tube with a string as can be shown by the figure on the right. She weighed all the contents together on a weighing balance. The mass obtained was 160.2 g.

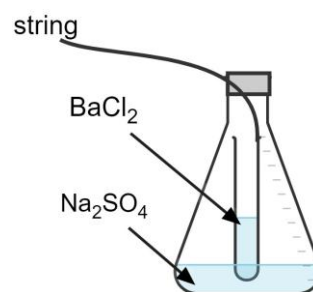

She turned the setup upside down (holding the corked conical flask) so that the two solutions mixed well together. She then swirled the conical flask several times making sure that both solutions mix well. Jane then left the setup to stand for 10 minutes making sure that the reaction was complete. A white precipitate forms at the bottom of the conical flask. After 10 minutes, allowing complete reaction, she weighed the contents again and found the mass to be 160.2 g.

- i. Write a balanced chemical equation including state symbols, of the reaction taking place. _____ (3)

- ii. Explain why the same value was obtained before and after the experiment.

 _____ (3)

3. Explain the following statements by referring to the kinetic theory.

- a. The melting point of the metal gallium is 29.7 °C. When gallium is held in one's hand it forms a liquid.

 _____ (2)

- b. A layer of water is placed carefully over a red dye. After two days the red dye spread throughout the water.

 _____ (2)

- c. A bottle of perfume is opened at the front of the classroom but after a while you can smell the perfume from the back of the classroom.

 _____ (2)

- d. The relative molecular mass of four gases is: carbon dioxide 44, methane 16, nitrogen 28 and oxygen 32. Put these gases in order of their diffusion rate with the fastest first.

 _____ (2)

(17 marks)

4. The diagram below shows the heating curve of a metal.

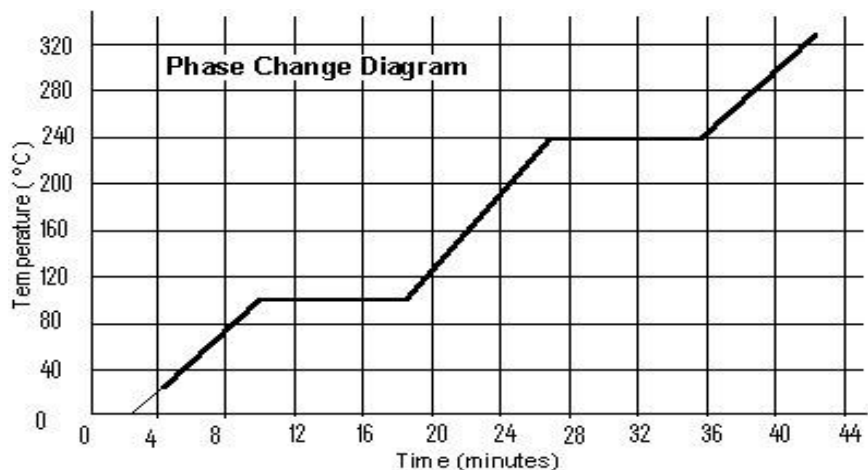

- a. State the melting point of the metal. _____ (1)
- b. State the boiling point of the metal. _____ (1)
- c. What happens to the temperature as the substance changes state?
 _____ (1)
- d. How can you say that the substance is not water?

 _____ (2)
- e. What is a cooling curve and how is this different from a heating curve?

 _____ (2)

(7 marks)

5. The state at which a substance exists at room temperature depends upon its melting and boiling in relation to room temperature. If room temperature is 25 °C, in which state of matter will each of the following substance exist:

Substance	Melting point /°C	Boiling point /°C	State
A	-183	-88	
B	80	216	
C	-89	118	

(3 marks)

6. Complete the following sentences using one word or a phrase from the list below. The words can be used ONCE or not at all:

compound, mixture, element, condensation, sublimation,
squeeze, evaporation, diffusion, vibrate

- a. A pure substance that cannot be split up into anything simpler is called an _____ . (1)
- b. When a solid changes directly to a gas, this is called _____. (1)
- c. When baking a cake, it smells in every corner of the house because of _____. (1)
- d. In a solid the particles are very close together and can only _____ about fixed positions. (1)
- e. Iron and sulfur are put on a filter paper and mixed to form a _____. They are then placed in a crucible and heated over a Bunsen burner and tripod to form a black _____ of iron(II) sulfide. (2)
- (6 marks)
7. The kinetic theory states that all matter is made up from small indivisible particles as shown below.

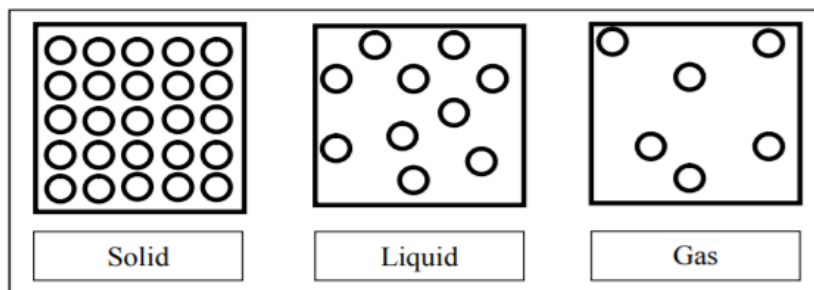

- a. Fill in the spaces with appropriate words/phrases:
These small indivisible particles are known as _____. Elements have only _____ type of particles while compounds and mixtures have _____ than one type of particle. Steel is an alloy. It is an example of a _____ (4)
- b. Use the kinetic theory to explain why:
- i. Solids have a fixed shape.
- _____
- _____ (1)
- ii. Liquids can take the shape of a container.
- _____
- _____ (1)

iii. Gases can be compressed easily.

_____ (1)

c. The diagram below shows what happens when bromine gas present in a gas cylinder and air in a separate gas jar are mixed.

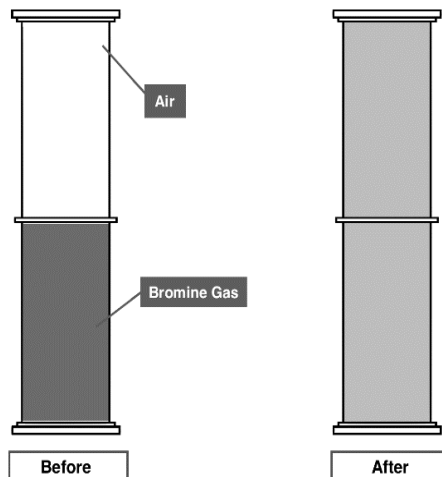

i. What is the name of the process taking place?

_____ (1)

ii. Explain what is observed after a couple of hours in terms of particles.

_____ (2)
 _____ (10 marks)

8. The graph below shows how the temperature of a substance varies with time as it is cooling down.

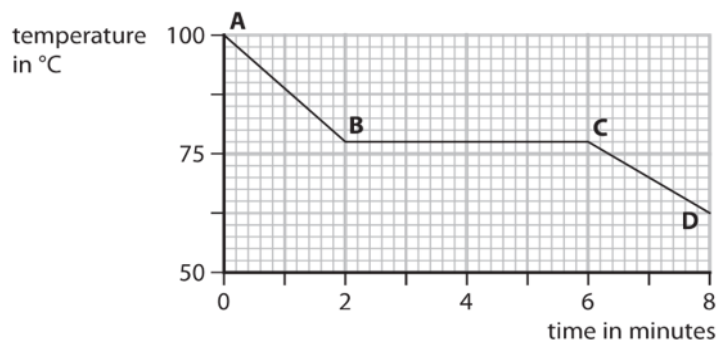

a. Fill in the spaces with suitable words.

The figure shows the _____ curve of a substance. From point A to point B the substance is in a _____ state and from point _____ to point _____ the substance is a liquid. The conversion to a liquid happens between the _____ and _____ minute.

(5)

- b. The table below shows the melting and boiling points of substances W, X, Y and Z.

Substance	Melting point (°C)	Boiling point (°C)
W	-220	-188
X	-101	-34
Y	-7	59
Z	114	184

Using the information in the table above:

- i. Give the letter of the substance that is a solid at 20 °C _____ (1)
- ii. Give the letter of the substance that is a liquid at 50 °C _____ (1)
(7 marks)

9. A student is given some solid wax. He needs to turn this into a liquid and determine the melting point of the wax.

- a. Using TWO diagrams, draw the particle arrangement in solid wax and in the melted wax.

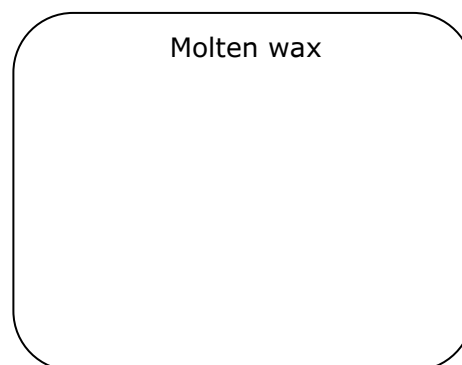
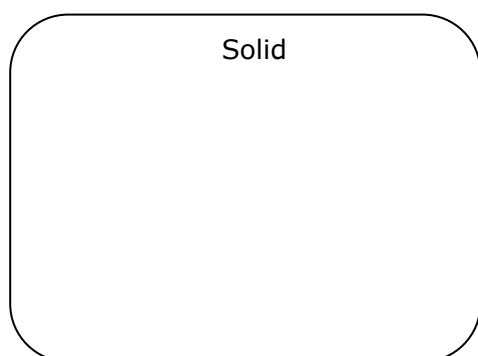

(2)

- b. Dry ice (solid carbon dioxide) forms a gas without having a liquid stage at a temperature of -78 °C at atmospheric pressure.

- i. What is this process called? _____ (1)
- ii. Sketch the heating curve of dry ice labelling both the x-axis and the y-axis as well as any changes of state taking place.

(2)

- c. Explain what happens to the particles as solid dry ice reaches room temperature.

(2)
(7 marks)

6 Further questions

1. The atoms of the following elements can react by losing or gaining electrons to form ions.
 a. Using the information given and the Periodic Table complete the following table.

Element	Atomic number	Electron configuration	Electrons lost or gained	Noble gas configuration attained	Ion formed
Sodium	11	2, 8, 1			
Chlorine	17				
Magnesium					
Oxygen	8				
	13	2, 8, 3			

(5)

- b. Explain why sodium is found in Group 1 of the Periodic Table.

_____ (1)

- c. Write the chemical formula of the compound formed when magnesium reacted with chlorine.

_____ (1)

- d. Draw a dot-cross diagram of the bonding present in the compound between magnesium and chlorine. Show all electron shells.

(3)

- e. The compound formed between magnesium and chlorine has a high boiling point. Explain in terms of bonding and structure why this is so.

 _____ (2)

(12 marks)

1. Work out the relative molecular mass (RMM) of the following substances.
 - a. Chlorine gas _____ (2)
 - b. Bromine liquid _____ (2)
 - c. Iodine crystals _____ (2)
 - d. Ozone gas _____ (2)

(8 marks)

2. Calculate the RMM of the following molecules.
 - a. Ammonia gas _____ (2)
 - b. Carbon monoxide _____ (2)
 - c. Methane gas _____ (2)
 - d. Sulfur dioxide _____ (2)

(8 marks)

3. Find the relative formula mass (RFM) of the following compounds.
 - a. Copper(II) oxide _____ (2)
 - b. Magnesium sulfate _____ (2)
 - c. Zinc nitrate _____ (2)
 - d. Ammonium carbonate _____ (2)
 - e. Calcium phosphate _____ (2)

(10 marks)

2. Methane is found in natural gas and is widely used as a fuel.
 - a. Draw a dot-cross diagram, showing outer electrons only, to illustrate the bonding present in methane.

(2)

- b. Methane can undergo complete or incomplete combustion. Name the factor that affects whether a fuel undergoes complete or incomplete combustion. Explain your answer.

(3)

c. The following experiment is carried out to find the products of combustion of wax.

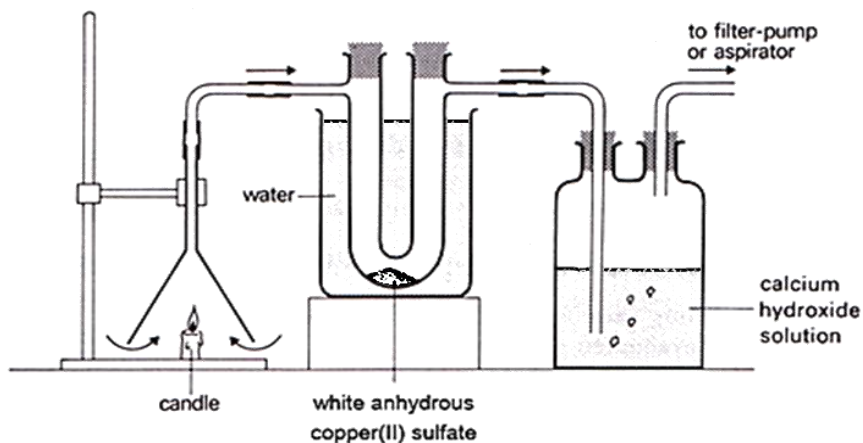

i. Describe what you would observe inside the U-tube. Name the gas identified in the U-tube.

_____ (2)

ii. Describe what happens to the calcium hydroxide solution.

_____ (1)

iii. Write a balanced chemical equation for the reaction taking place inside the wash bottle containing calcium hydroxide.

_____ (2)

iv. Soot is observed on the inside of the funnel. Explain why soot is formed.

_____ (1)
(11 marks)

3. The diagram below shows the laboratory preparation and collection of oxygen.

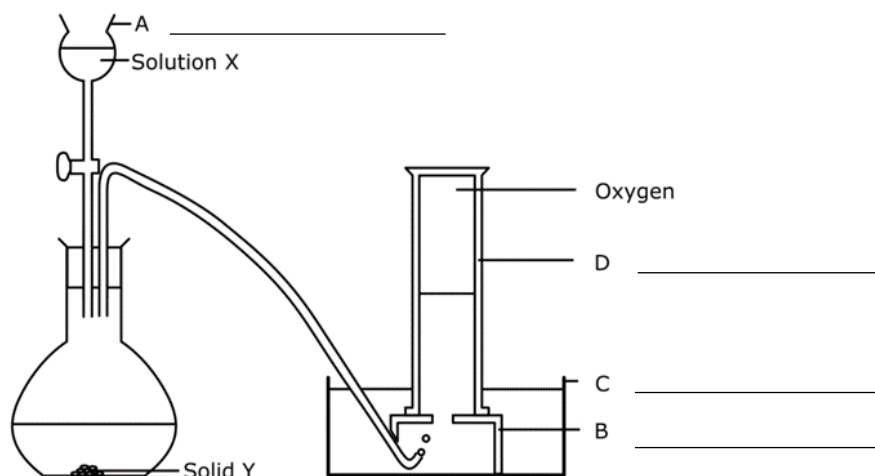

a. Give the names of the items of the apparatus labelled A to D. (4)

b. Name the solution X and the solid Y.

X: _____ Y: _____ (2)

- c. Give a balanced chemical equation for the decomposition of solution X including state symbols.

_____ (1)

- d. State the function of solid Y.

_____ (1)

- e. Explain why it is possible to collect oxygen over water.

_____ (1)

- f. Metals and non-metals can burn in oxygen to give oxides.

- i. Give the nature of the following oxides.

Oxide	Nature of oxide (acidic/ basic/ neutral)
carbon monoxide	
nitrogen dioxide	
magnesium oxide	
copper(II) oxide	
sulfur dioxide	

(5)

- ii. Calcium oxide dissolves in water but iron(II) oxide does not. Describe an experiment to show that each one shows basic properties.

_____ (2)

(16 marks)

4. A cotton wool is soaked with concentrated hydrobromic acid and releases hydrogen bromide gas. Another cotton wool is soaked with concentrated ammonia solution which releases from ammonia gas. Both cotton wools are placed at the opposite end of a glass tube as shown in the diagram below. After some time, a white ring of ammonium bromide is formed in the tube.

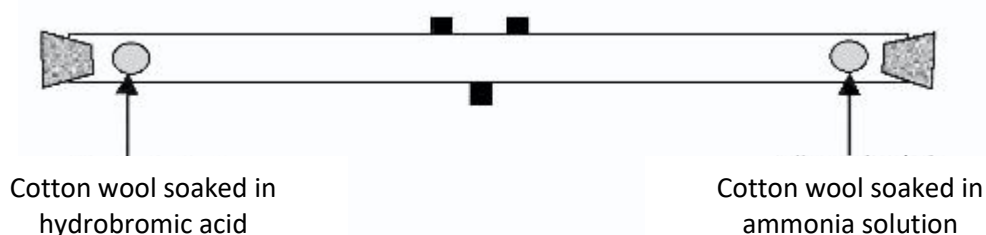

- a. Both gases diffuse along the tube. Explain the term diffusion.

_____ (2)

- b. Explain why the two cotton wools are inserted at the same time.

_____ (2)

- c. Calculate the RMM of each gas and determine which gas travels faster.

_____ (2)

- d. Mark where the white ring appears in the diagram above. (1)

- e. Write a balanced chemical equation for the reaction taking place.

_____ (1)

- f. Predict what would be observed in this experiment is carried out at a lower temperature. Explain your answer in terms of particles.

_____ (2)

- g. Concentrated ammonia solution and concentrated hydrochloric acid are corrosive. Give a safety precaution that needs to be taken.

_____ (1)

(11 marks)

5. There is a very careful balance in nature so that the level of carbon dioxide in the atmosphere remains constant.

- a. Mention one natural process by which carbon dioxide forms in air.

_____ (1)

- b. Mention one natural process by which carbon dioxide can be removed from the air.

_____ (1)

- c. The balance in nature has now been disturbed so that more carbon dioxide is being produced than is removed. Suggest **two** reasons for this.

_____ (2)

- d. Life can thrive on Earth due to the greenhouse effect. Due to certain gaseous emissions today we have an enhanced greenhouse effect.

- i. Describe the greenhouse effect.

_____ (2)

- ii. Mention **two** greenhouse gases, other than carbon dioxide.

_____ (2)

iii. List **three** harmful consequences of the enhanced greenhouse effect.

(3)
(11 marks)

6. The table below shows values for the solubility of copper(II) sulfate.

Solubility (g/100g of water)	14	20	28	40	56	77
Temperature (°C)	0	20	40	60	80	100

a. Plot the solubility curve for copper(II) sulfate. (5)

b. What is the solubility of copper(II) sulfate at 50 °C? _____ (1)

c. Calculate the mass of copper(II) sulfate which will saturate 10 g of water at 30 °C.
_____ (2)

d. At what temperature will 60 g of copper(II) sulfate saturate 100 g of water?
_____ (1)

e. Calculate the mass of copper(II) sulfate produced when a solution cools from 90 to 30 °C.
_____ (1)
(10 marks)

7. Dione is a moon of the planet Saturn. In March 2012 scientists verified that Dione has an atmosphere which is made up of mainly oxygen. The discovery was made using instruments on board the unmanned Cassini spacecraft.

a. Describe a chemical test which proves the presence of oxygen gas.
_____ (1)

b. State **two** physical properties of oxygen gas.

_____ (2)

c. Oxygen can combine with many different elements.

i. Draw a dot-cross diagram to represent the bonding present in sodium oxide. Draw all electron shells.

(2)

- ii. Draw dot-cross diagram to represent the bonding present in water, showing outer electrons only.

(2)

- d. Explain in terms of structure and bonding why the melting point of sodium oxide is higher than that of water.

(4)

(11 marks)

8. Four samples of water, A, B, C and D, were tested for hardness. Soap solution was added, with shaking, to each of the four 20.0 cm³ samples of water. The volume of soap solution required to produce 1 cm height of lather was recorded. The experiment was repeated, with fresh boiled samples of water and then again with fresh samples of water which had been treated with washing soda. The results of the experiment are shown below.

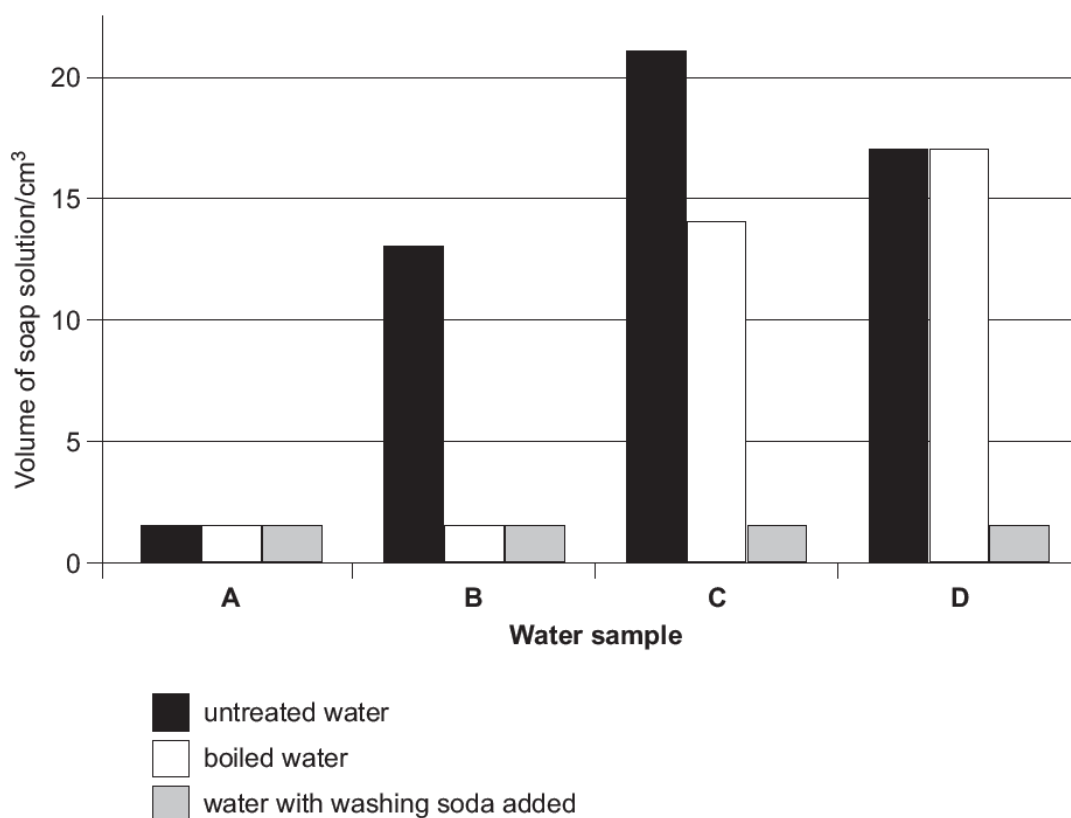

a. What is meant by the term hard water?

_____ (1)

b. Which one of the samples, A, B, C or D is the hardest water? Explain your answer.

_____ (2)

c. What type of hardness is present in the following samples? Explain your answer.

i. Sample B

_____ (2)

ii. Sample D.

_____ (2)

d. Name another method which would give similar results to washing soda.

_____ (1)

(8 marks)

9. The figure below shows some reactions of dilute sulfuric acid.

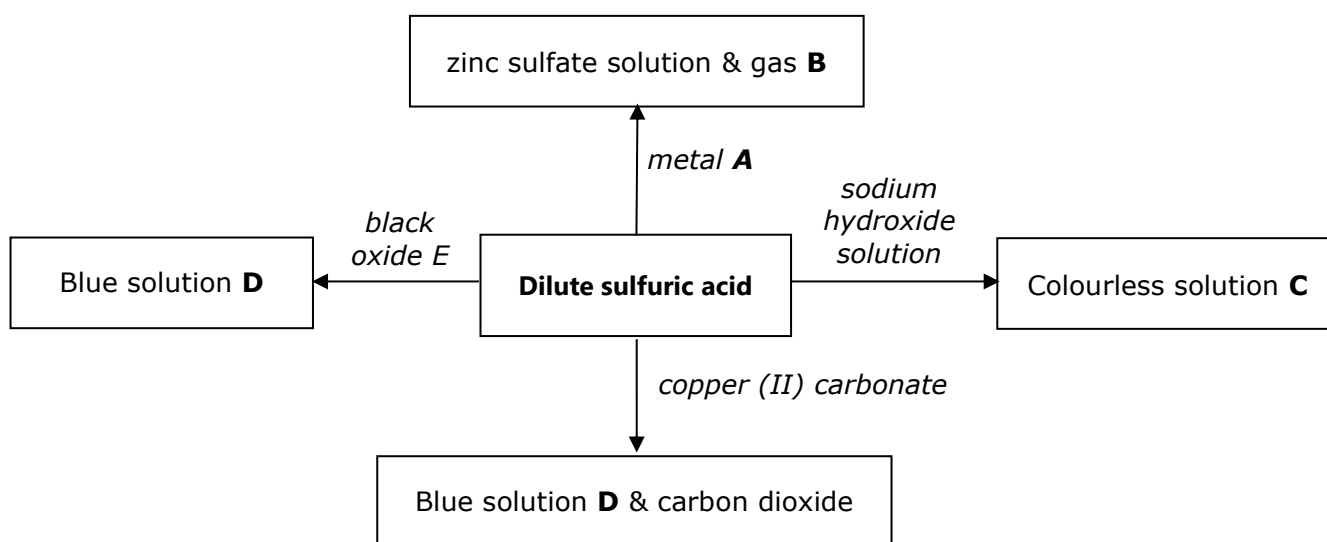

a) Give the name for

i. Metal A

ii. Gas B

iii. Colourless solution C

iv. Blue solution D

v. Black oxide E

(5)

- b) Describe the main steps that are used to prepare **crystals of salt D** from the reaction of dilute sulfuric acid and copper(II) carbonate (a green powder). The first two steps have been done for you.

Procedure

1. 50cm³ of sulfuric acid are measured using a measuring cylinder and poured in a beaker.
2. The acid is heated gently.

(4)

- c. Write a balanced chemical equation for the reaction of copper(II) carbonate and sulfuric acid.

(1)

(10 marks)

10. Some students prepare and collect a small amount of magnesium carbonate. The only chemicals available are potassium carbonate, ammonium chloride, magnesium chloride and calcium carbonate, distilled water and all apparatus are available.

- a. Is magnesium carbonate soluble in water?

(1)

- b. From the above list select two suitable reagents to prepare magnesium carbonate.

(2)

- c. Write a balanced chemical equation for the reaction taking place. Include state symbols.

(3)

- d. Describe a method to carry out this preparation and collect a pure, dry sample of magnesium carbonate.

(4)

(10 marks)

